

LG HVAC Solution

Air Cooled Screw Chiller

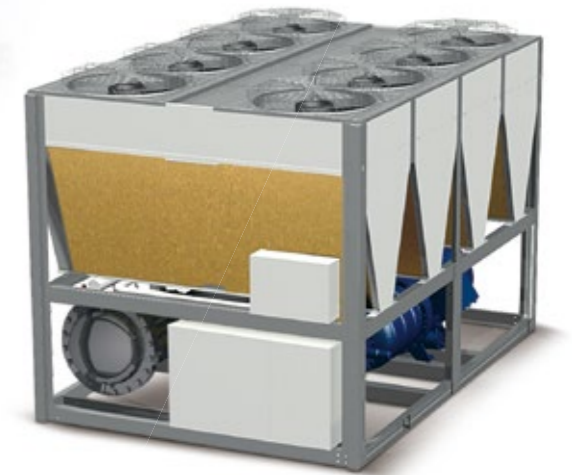

- The copyright of this catalog belongs to LG Electronics, and unauthorized reprinting or redistribution without prior approval may result in sanctions under relevant laws.
- For continual product development, LG reserves the right to change specifications or designs without notice.
- This catalog uses recyclable paper.
- 2022 LG Electronics. Printed in Korea. Oct. 2022

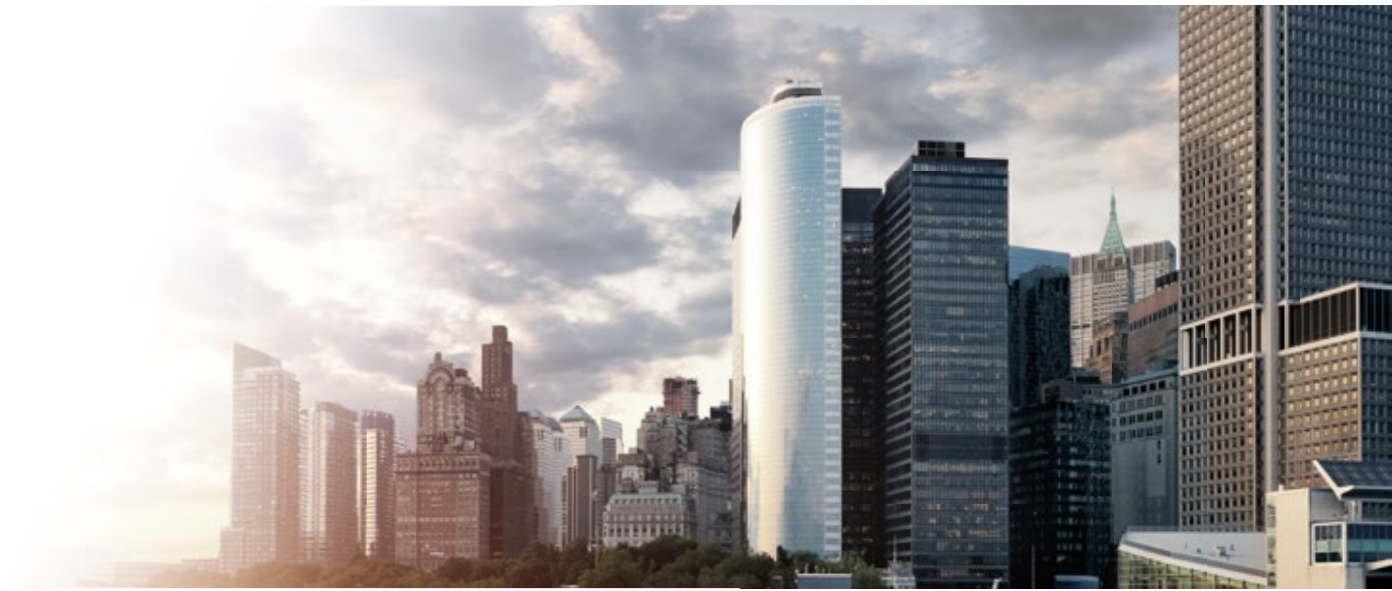
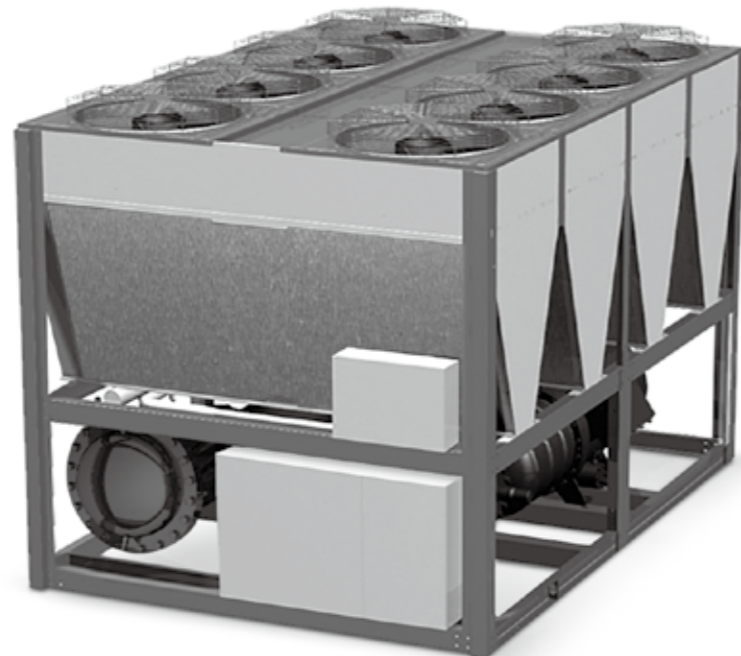
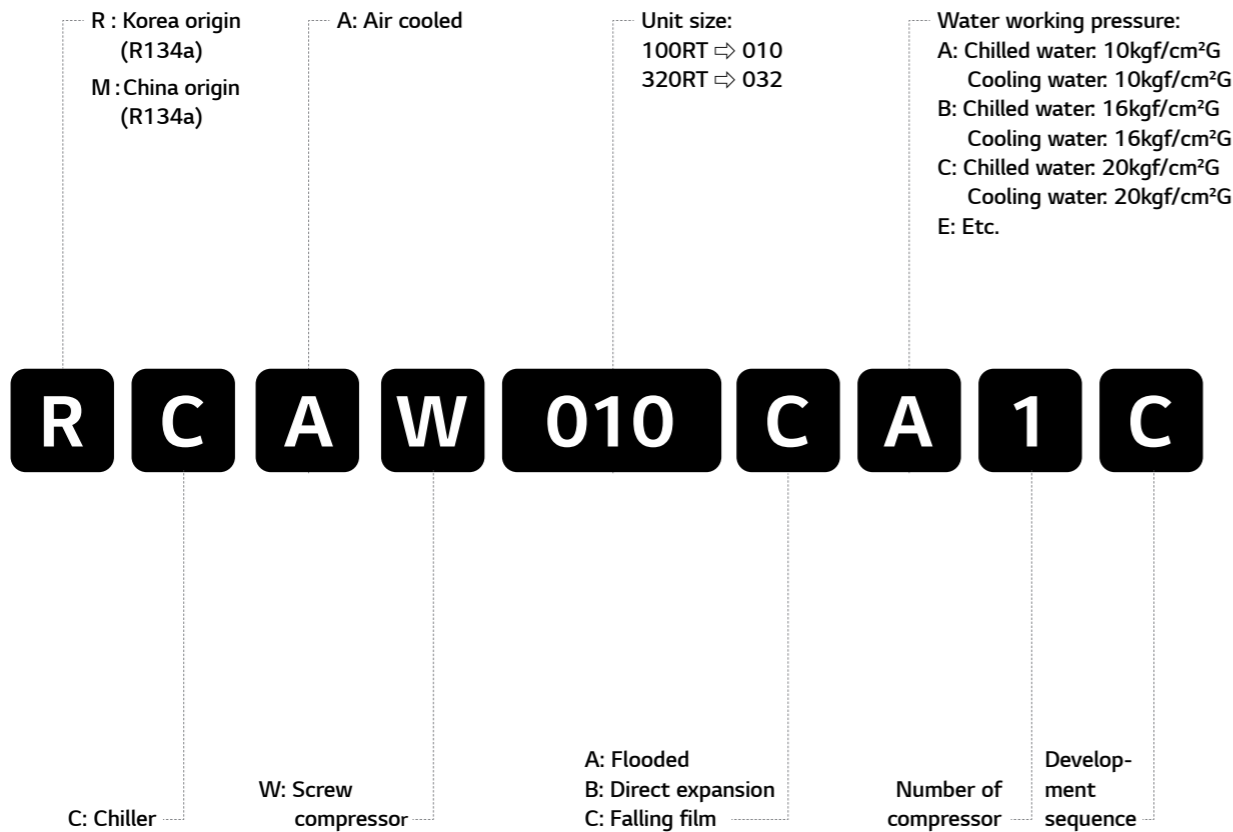

Contents

- 02 Nomenclature
- 03 Introduction
- 05 Equipment overview
- 09 Accessories and options
- 10 Power connection
- 11 Specification
- 35 Outline dimension
- 37 Foundation
- 39 Installation
- 42 Guide specification

Line up

Model			[usRT]									
			50	100	150	200	250	300	350	400	450	500
	RCAW Series	50Hz		84								503
		60Hz		78								
	MCAW Series Standard	50Hz		82								509
		60Hz		80								
	MCAW Series High	50Hz		78								495
		60Hz		78								

* The above range is based on the nominal tonnage.

LG Air cooled water chillers are complete, self-contained automatic refrigerating units that include the latest in engineering components arranged to provide a compact and efficient unit. Each unit is completely assembled; factory wired, evacuated, charged, tested and comes complete and ready for installation.

Each unit consists of multiple air-cooled condensers with integral sub-cooler sections, one or more accessible semi-hermetic twin screw compressors, star-delta starters, high efficiency evaporator, and complete refrigerant piping. Liquid line components included are manual liquid line shutoff valves, charging valves, filter-driers, liquid line solenoid valves, sight glass/moisture indicators, and electronic expansion valves.

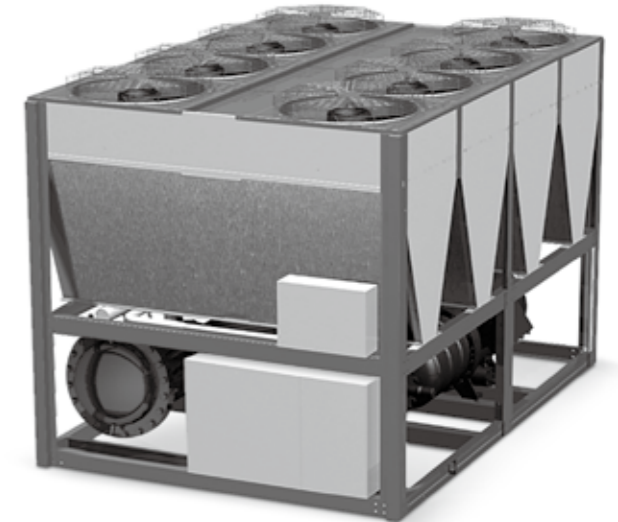

- High-performance compressor manufactured by specialized manufacturer is adopted to ensure that the chiller is economical and durable with low vibration and low noise.
- Highly integrated motherboard is adopted and hence the function is strong and reliable.
- Advanced control algorithm is adopted to control chiller in advance and hence avoid frequent stoppage of chiller.
- We have set complete safety protection function in order to make chiller safely and reliably run.
- The linkage control and remote monitoring function of peripheral equipment ensure that the chiller can run safely and the operation and monitoring are convenient.
- The selection of excellent raw materials and fittings is the key to guaranteeing chiller quality.

Excellent reliability and powerful operation

The cutting-edge design of Air-cooled screw chiller accomplishes high performance and reliability for industrial and commercial market.

LG Air-cooled screw compressors are precisely machined from solid compound metal bar using profound cutting process. Tolerance is maintained within a few microns just like one-tenth hair thickness. Robust components with highly skilled assembling process help the compressor last for a long time.

LG condenser production technology is already well-known to worldwide air conditioning manufacturing industries because of its leading technologies.

World class high efficiency

Top level efficiency is in accordance with AHRI Standard 550/590. Optimized compressor design including a rotor and a slide valve is suitable for comfort cooling applications.

The rotor is designed to work efficiently for different pressure ranges covering air conditioning and refrigeration application.

The slide valve controls the cooling capacity by controlling the position of the slide where refrigerant suction starts using internal pressure difference between discharge and suction.

LG air cooled screw chiller has 4 steps capacity control(100, 75, 50, 25%) capability which is optimized for part-load condition.

Precise rotor tip clearance provides excellent energy efficiency in the screw rotary compressor because this reduces leakage from high pressure to low pressure side during compression, achieving top class COP.

The evaporator uses internally grooved tubes having helical angle which have enhanced the water side heat transfer performance. The outside of the tube is of optimum shape which has highly enhanced performance for film-wise evaporation with R134a. The V-shape of condenser allows the largest heat transfer surface area for the same footprint, resulting in largest heat transfer performance when the configuration is optimally designed.

The LG V-shape condenser coil was designed by using numerical and experimental analysis, having optimum air flow path to optimize heat rejection performance.

Also, the enhanced condenser fin geometry allows the optimum heat transfer performance at small air side pressure drop, and this reduces the fan-motor power consumption. The fin is pre-coated to prevent corrosion at normal conditions and epoxy coated fin condenser which is sustainable in harsh conditions, is also available as option.

Low noise and low vibration

The unit was designed with a compact structure and robust assembly. The condenser fan is completed with high-efficiency wing style axial fan and direct driven motor for low sound level. The unit configures compressor sound insulation box(Optional), which makes LG chillers silent and stable.

Installation, start-up

- Small operating footprint fit most retrofit applications. (Compact model)
- Factory testing for high reliability.
- Factory-installed and tested controls help to reduce start up time and minimized extra cost.
- Display temperature and pressure for each component spot.

Compressor specification

- Semi-hermetic twin-rotor screw compressor.
- Direct-drive, low speed/RPM.
- Only three moving parts, resulting in high reliability.
- The slide valve has a unique profile, optimized for part-load conditions.
- Field serviceable and easy maintenance.
- Precise rotor tip clearance
- A refrigerant dispersing device is set internally to the compressor for motor cooling.

Factory testing / unit performance testing

LG air-cooled screw chillers are given with a complete functional test at the factory. LG computer-based testing programs completely check the components including sensors, wiring, electronics and microprocessor control functions.

LG promotes factory performance tests for air-cooled chillers and water-cooled chillers to show that we stand behind the products which are designed and built up.

The benefits of a performance test include verification of performance, prevention of operational problems, and assurance of a smooth start-up. Each compressor is run and tested to verify capacity and efficiency.

Structural strength analysis

Structure is designed to ensure stiffness for various disturbances by steps of structure modeling, meshing, excitation and evaluation.

Structural strength evaluation simulation

Aerodynamic analysis

Condenser part is appropriately designed by aerodynamic analysis like inlet and outlet uniform airflow design and dead zone reduction design.

Heat circulation evaluation simulation

Eco-friendly refrigerant R134a

System designed with Eco-friendly refrigerant R134a which does not harm the ozone layer & protects the environment.

The HCFC(R22, R123) series cannot be produced any more from 2020 according to the Montreal Protocol for protection of ozone layer.

AHRI certification program and standards and codes

The performance of the screw chiller complies with Air

Conditioning, Heating, and Refrigeration Institute(AHRI) latest standards program(AHRI Standard 550/590).

Providing independent, third-party verification, the AHRI regularly tests chiller to ensure compliance.



Chillers conform to the following Standards and Codes:

- AHRI 550/590 - Water chilling packages using the vapor compression cycle.
- ANSI/ASHRAE 34 - Number designation and safety classification of refrigerants.
- ASME Section VIII - Boiler and pressure vessel. (This code is only applied to product manufactured in Korea)
- CE - Conform to CE testing services for construction of chillers and provide CE listed mark
- ETL - Conforms to ANSI/UL STD 1995 certified to CAN/CSA STD C22.2.
- GB/T 18430.1 - Water chilling(Heat pump) packages using the vapor compression cycle - part 1: water chilling(Heat pump) packages for industrial & commercial and similar applications.

(This code is only applied to product manufactured in China)

Equipment overview

Semi-hermetic twin rotor screw compressor

The semi-hermetic screw compressor is developed especially for applications in air-conditioning and refrigeration. With high operating load design, each compressor is of high efficiency and reliability in all operating conditions. Each compressor has the latest and advanced 5-to-6 Patented Screw Rotor Profile designed to ensure high capacity and efficiency in all operating conditions.

The compressor is equipped with separated radial and axial bearings, liquid injection and economizer connection, PTC motor temperature thermistors and discharge temperature thermistors, a motor protector, and oil level switch and oil pressure differential switch and other accessories. The complete accessories and their new designs guarantee the compressor has the best reliability, longest bearing life during heavy duty running and strict operating conditions.

The slide valve for capacity control is located in the compressor chamber. The slide valve is actuated by injection of pressurized oil into the cylinder from the oil sump as well as

bypass of oil through solenoid valves in each oil lines with pressure differential.

The screw compressors are equipped with either 3-step/4-step capacity control system or continuous(Stepless) capacity control system. Both of the capacity control systems consist of a modulation slide valve, piston rod, cylinder, piston and piston rings. The slide valve and the piston are connected by a piston rod. The principle of operation is using the oil pressure to drive the piston in the cylinder. The lubrication oil flows from the oil sump through the oil filter cartridge and capillary then fills into the cylinder due to the positive oil pressure bigger than the right side of spring force plus the high pressure gas. The positive pressure differential causes the piston to move toward the right side in the cylinder.

When the slide valve moves toward the right side, the effective compression volume in the compression chamber increases. This means the displacement of refrigerant gas also increases, as a result the refrigeration capacity also increases. However, when any of the step solenoid valve(For 4-step capacity control system) is opened, the high pressure oil in the cylinder bypasses to the suction port, which causes the piston and the slide valve to move toward the left side, and then some of the refrigerant gas bypasses from the compression chamber back to the suction end.

As a result, the refrigeration capacity decreases because of the reduction of displacement of refrigerant gas flowing in the system. The piston spring is used to push the piston back to its original position, i.e. minimum load position in order to reduce the starting current for the next starting.

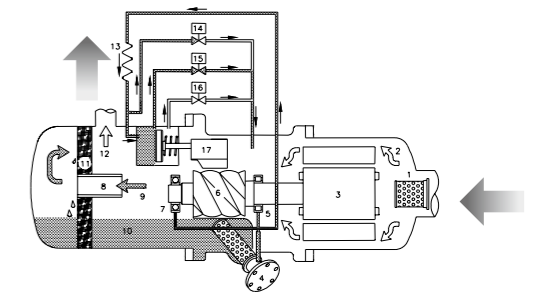

4-step capacity control

No	Component	No	Component
1	Suction filter	10	Lubricant
2	Gas in(Low pressure)	11	Oil separator cartridge
3	Motor	12	Gas out (High pressure without oil)
4	Oil filter cartridge	13	Capillary
5	Suction bearings	14	Solenoid valve, SV2
6	Male rotor	15	Solenoid valve, SV1
7	Discharge bearings	16	Orifice
8	Oil separator baffle	17	Slide valve
9	Gas out(High pressure with oil)		

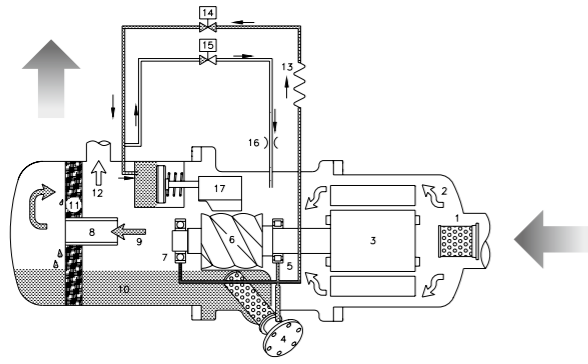

Step-less capacity control

No	Component	No	Component
1	Suction filter	10	Lubricant
2	Gas in(Low pressure)	11	Oil separator demister
3	Motor	12	Gas out(High pressure without oil)
4	Oil filter cartridge	13	Capillary
5	Suction bearings	14	Solenoid valve(Min. %), SV 25% / 33%
6	Male rotor	15	Solenoid valve (50% of full load), SV 50%
7	Discharge bearings	16	Solenoid valve(75% / 66% of full load), SV 75% / 66%
8	Oil separator baffle	17	Slide valve
9	Gas out(High pressure with oil)	*	For RC2-100, 140 & 180 the SV50% omitted

Heat exchanger

Evaporator falling film type

"Falling film" shell and tube type evaporator is having refrigerant in the shell and chilled water inside the tubes.

Advantage of this type evaporator is higher heat transfer performance and reduced refrigerant charge.

Distributor located on the top side of inside shell makes uniform flow of refrigerant, this refrigerant flows downward by gravity as a continuous film.

The shell is of welded carbon steel construction with steel tube sheets and copper heat exchange tubes. Removable steel water boxes at both ends of the cooler allow tube cleaning without disturbing the refrigerant circuit.

Tubes are mechanically expanded into tube sheets with double grooves to ensure leak tight and trouble free operation. Multiple compressor/circuit chillers have coolers with separate refrigeration circuits for each compressor.

Each refrigeration circuit is provided with its own pressure relief valve. All chillers are fitted with drain valves on the removable heads and shell. All coolers are factory insulated

with 19mm of closed cell expanded synthetic rubber with all joints vapor sealed.

Air cooled condenser

Condenser coils are constructed from copper tubes with spiral grooves on their inside surface to maximize heat transfer efficiency. The two types of condenser fin can be provided as a standard based on customer's request. The one is that aluminum condenser fins have a corrosion resistant and hydrophilic coating to minimize dust and moisture accumulation and ensure a long working life. The fins have rippled and louvered surfaces to improve heat dissipation efficiency.

The other one is that LG's patented chloride-induced corrosion-resistant Goldfin™ reduces heat exchanger corrosion. This specially developed coating offers maximum protection, even in the most humid of conditions.

Each condenser section comprises coils in a reversed V arrangement. Condenser fans are axial type using designed s-shaped blade. Therefore it makes high air flow and low vibration and sound with the combination of this technology, chiller can be operated in ambient temperature up to 52°C (125°F). Fan motors are waterproof rated to IP54 with class 'F' insulation suitable for operation in temperatures from -20°C to 65°C(-4°F to 150°F).

Electronic expansion valve

Electrically operated expansion valves is used for precise liquid injection in evaporators. This EXV are designed for HFC/HCFC conditions, providing 34 bar(493 psig) working pressure.

Balanced design providing bi-flow operation as well as solenoid tight shut-off function in both flow directions at MOPD(Maximum Operating Pressure Differential) 33 bar(478.6 psig). This valve controls refrigerant flow for different operating conditions by change orifice size to increase or decrease flow area through the valve. This valve is controlled by microprocessor signal.

Control

Controller system information

Generally controller consist of Display, Master, Slave and Relay board. Each board connect with RS485 communication and include analog input/output, digital input/output channel.

- 7 inch color LCD touch screen with high resolution
- Operation scheduling function
- Real time trend display
- Web Access(Additional accessory)

- Running data acquisition
- Easy-to-read display of operational data
- Certified EMI/EMS
- Communication supported: Modbus, RS485(Standard)
- Language: English / Chinese / Korean

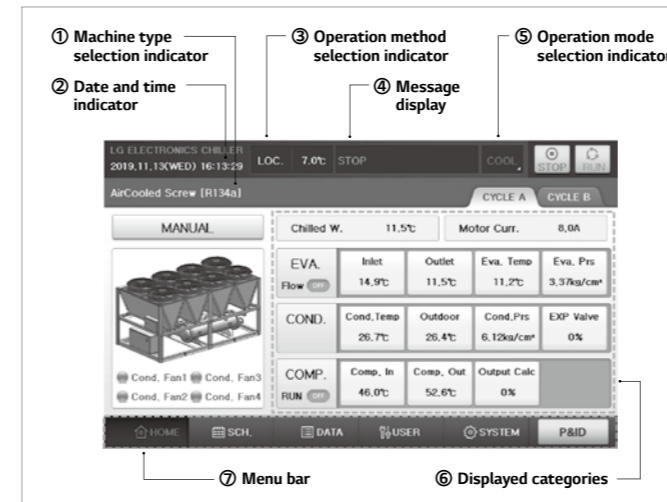

Controller front view

- ① Machine type selection indicator
It show the currently selected model. You can check detail from 'Control Information set' part.
- ② Date and time indicator
It show the current time. You can check detail from 'Sys. Info.(System information)' part.
- ③ Operation method selection indicator
It show the currently selected control mode. You can check detail from 'User set' part.
- ④ Message display
It show the message about status of product.
- ⑤ Operation mode selection indicator
It show the currently selected run mode. You can check detail from 'User set' part.
- ⑥ Displayed categories
It show the currently information of product.
- ⑦ Menu bar
It show the functions for menu operation bottom.

Controller system composition diagram

Master board and slave board have the same hardware and they are set as master or slave by DIP switch setting. This board consist of analog input/output, digital input/output and communication connections.

BMS support function

Screw chiller's basic communication protocol is Modbus protocol, and it can be compatible with higher level

communication methods.

Communication protocol support

- Protocol and communication method
 - Standard : Modbus, RS-485
 - Option : BACnet, TCP/IP

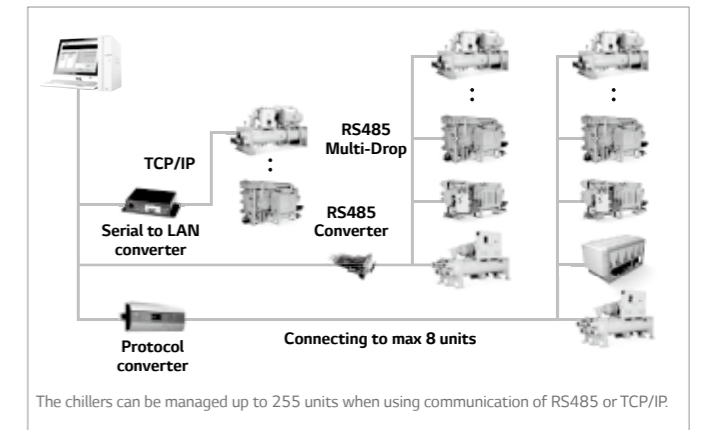

Detailed diagrams of BMS

NFB(Non-Fused Breaker) power disconnect switch

A non-fused disconnect is available as a factory-installed option for all units with single point power connection units. This option is that power supply is disconnected during service & repair

Suction service isolation valve

Suction service isolation valve is installed with unit for each refrigerant circuit as a standard.

Accessories and options

Compressor acoustic enclosure

The compressor acoustic enclosure can be provided as an option to reduce compressor sound levels.

This enclosure is constructed of painted panels and sound absorbing insulation for maximum sound attenuation. The panels and the sound foam provide sound damping effect. This panel fastened with bolt for service.

The enclosure is factory installed option.

Condenser

To have better protection against corrosion caused by salty air in seashore area or acid corrosive environment, these options are recommended to extend equipment life. The following options are provided with factory mounted.

- Pre Coating

The condenser coil is made of aluminum fins with pre-treated polyurethane coating.

• Copper fin

The heat exchanger unit is made with copper tube condenser coils having copper fins.(This is not recommended to use in area where they may be exposed to acid corrosive environment)

Evaporator options double thickness insulation

As a standard, the evaporator shell is insulated with 3/4” (19mm). As an option, it can be insulated with 1-1/2”(38mm).

General options vibration isolation

For installation on building roofs or in sensitive noise areas (Hospitals, studios and some residential areas) pre-selected spring type isolators with 1” or 2” deflection are available as a factory option – shipped with loose parts for field installation.

Power factor correction

Provide equipment with power factor correction capacitors as required to maintain a displacement power factor of 95% at all load conditions.

Single power point connection

For models installed with 2,3 and 4 compressors, to minimize job site installation cost and time, single point power connection can be provided as an option. If optional single point power connection is required, terminal block connections will be supplied at the point of incoming single point connection.

Air-Cooled Screw chiller standard summary

Items		Standard	Option
Comp.	*Power Supply(3Ph)	<input type="checkbox"/> 380V	<input type="checkbox"/> 400V <input type="checkbox"/> 415V <input type="checkbox"/> 440V <input type="checkbox"/> 460V <input type="checkbox"/> 480V
	*Hertz	<input type="checkbox"/> 50Hz	<input type="checkbox"/> 60Hz
	Capacity Control Type	<input type="checkbox"/> Step	
Control Panel	Communication	<input type="checkbox"/> Modbus	<input type="checkbox"/> BACnet <input type="checkbox"/> TCP/IP <input type="checkbox"/> etc()
	Protection Grade	<input type="checkbox"/> IP54	<input type="checkbox"/> etc()
Power Connection	<input type="checkbox"/> Standard(Multi,2-comp.)	<input type="checkbox"/> Single Power Connection	
Factory Wiring	<input type="checkbox"/> Open Wiring	<input type="checkbox"/> Flexible Wiring	
Starter Panel	*Supplied by	<input type="checkbox"/> Factory	<input type="checkbox"/> Supplied by Customer
	*Starter Type	<input type="checkbox"/> Y-Delta(Open)	<input type="checkbox"/> etc()
	*Mounted Type	<input type="checkbox"/> Unit Mounted	<input type="checkbox"/> Stand Alone
	Misc. Options	<input type="checkbox"/> N/A	<input type="checkbox"/> Ground Fault Protection <input type="checkbox"/> Power Factor Correction Capacitor
	Protection Grade	<input type="checkbox"/> IP54	<input type="checkbox"/> Integrating Watt-meter
	Internal Inspection Lamp	<input type="checkbox"/> N/A	<input type="checkbox"/> etc()
EVAP.	*Waterbox Pressure	<input type="checkbox"/> 150 psig(10kg/cm ²)	<input type="checkbox"/> 230 psig(16kg/cm ²) <input type="checkbox"/> 300 psig(20kg/cm ²)
	Flow Proof Type(Ref.)	<input type="checkbox"/> Relief V/V(Single)	<input type="checkbox"/> Relief V/V(Dual)
	Nozzle Type	<input type="checkbox"/> ANSI-Flange	<input type="checkbox"/> ANSI-Victaulic(AGS) <input type="checkbox"/> ANSI-Victaulic(OGS) <input type="checkbox"/> etc()
	Flow Proof Type(water)	<input type="checkbox"/> Flow Switch	<input type="checkbox"/> DP Switch
COND.	Fan Control(In all season)	<input type="checkbox"/> N/A	<input type="checkbox"/> Yes
	Fin Coating	<input type="checkbox"/> Standard(Gold Fin)	<input type="checkbox"/> BlyGold Fin <input type="checkbox"/> etc()
*Refrigerant Charge	<input type="checkbox"/> Separated Shipping	<input type="checkbox"/> Factory Charge <input type="checkbox"/> Customer Supplied	
Packing	<input type="checkbox"/> Shrink film	<input type="checkbox"/> Wood Packing	
Insulation	<input type="checkbox"/> N/A	<input type="checkbox"/> 19mm <input type="checkbox"/> 38mm <input type="checkbox"/> etc()	
Casing(Shell)	<input type="checkbox"/> N/A	<input type="checkbox"/> Yes	
*Sound Attenuator	<input type="checkbox"/> N/A	<input type="checkbox"/> Yes	
Isolation	<input type="checkbox"/> Neoprene PAD	<input type="checkbox"/> Spring 1inch	
Anchor Bolt for Foundation	<input type="checkbox"/> N/A	<input type="checkbox"/> Yes	
Counter Pipe Flange	<input type="checkbox"/> N/A	<input type="checkbox"/> Yes	
*Certification	<input type="checkbox"/> Standard(KGS)	<input type="checkbox"/> ASME VII Only <input type="checkbox"/> CE(PED) <input type="checkbox"/> PED <input type="checkbox"/> (C)UL(ETL) <input type="checkbox"/> GB	
Factory Performance Test&Process Inspec.	<input type="checkbox"/> N/A	<input type="checkbox"/> Report Only <input type="checkbox"/> Customer Witness <input type="checkbox"/> Process Inspection	
Operating Training	<input type="checkbox"/> N/A	<input type="checkbox"/> Yes	
Warranty-Compressor	<input type="checkbox"/> 1yr	<input type="checkbox"/> etc()	
Warranty-Ass'y	<input type="checkbox"/> 1yr	<input type="checkbox"/> etc()	
Labor Warranty	<input type="checkbox"/> N/A	<input type="checkbox"/> etc()	
Standard Specification	1) Color : Dawn Gray - Starter / Control Panel : Warm Gray 2) Standard Provide Emergency Stop Switch and Protection Guard		

* Standard specifications is partially changed depending on the chiller origin.

Single point connection

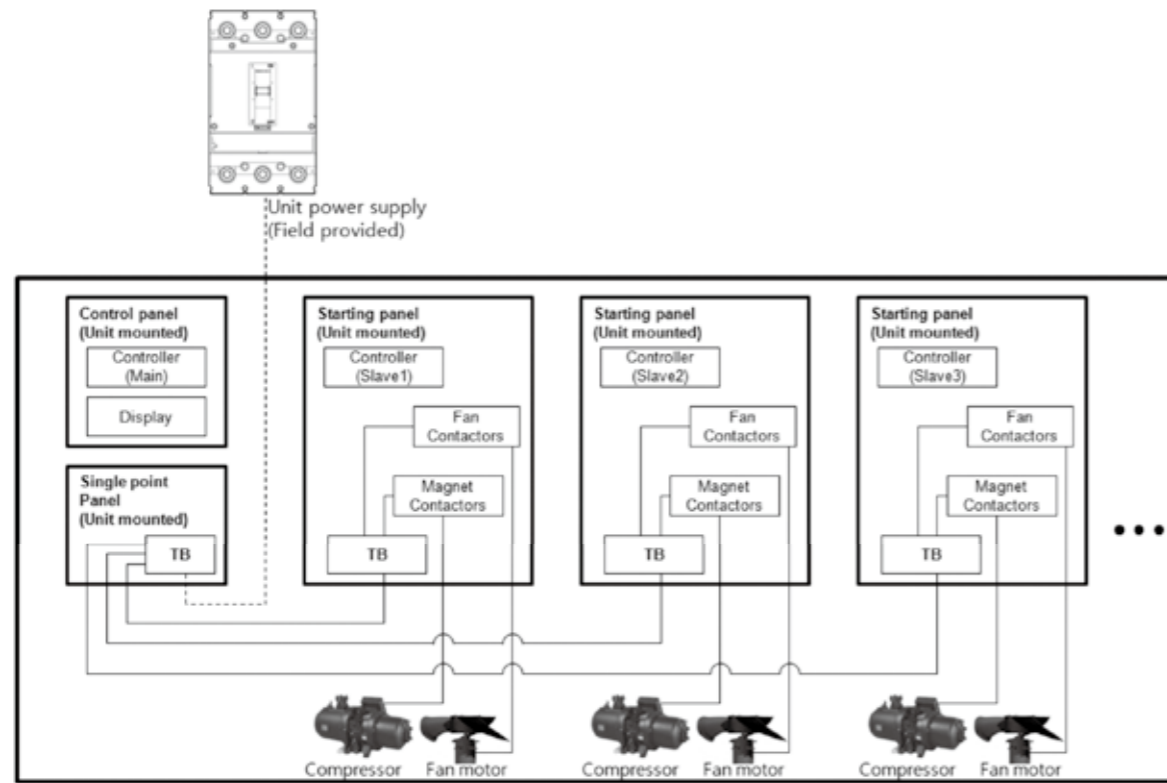

Multi point connection

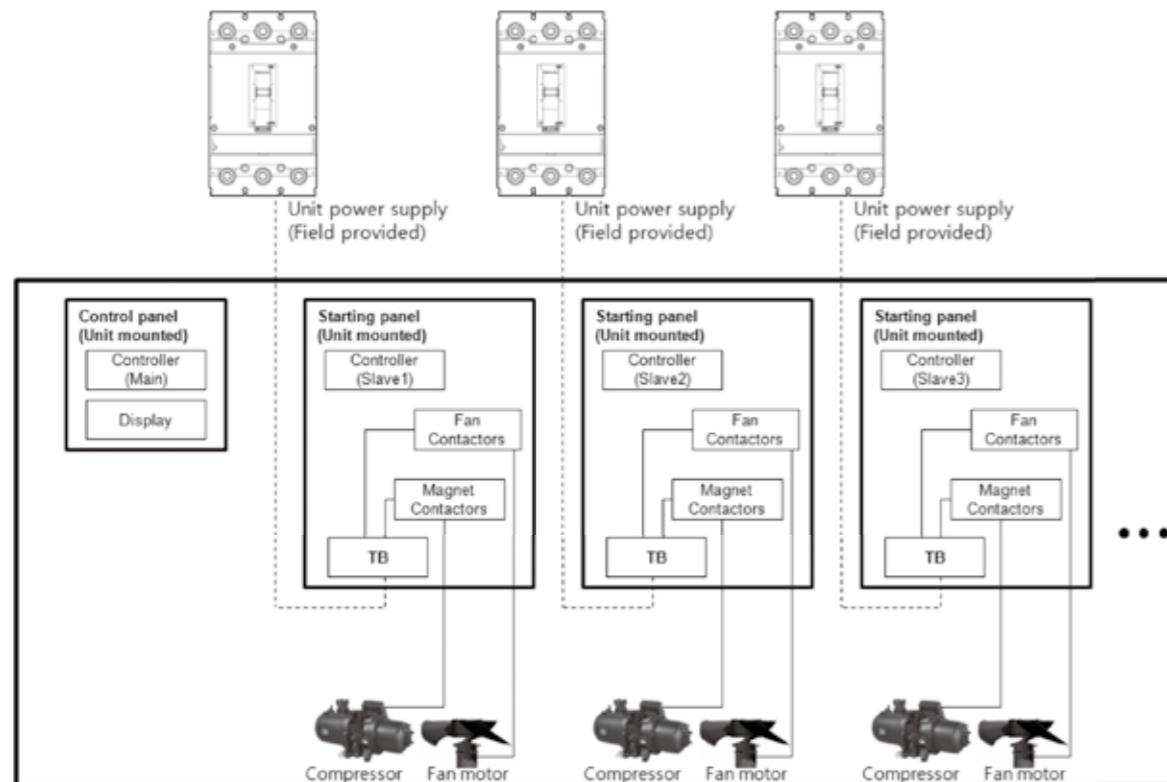

RCAW Series (60Hz)

Model	Units	RCAW008CA1C	RCAW010CA1C	RCAW012CA1C	RCAW014CA2C	
Unit Capacity	usRT	82	99	118	130	
	kW	287.4	347.7	415.6	458.8	
	kcal/h	247,120	298,968	357,352	394,497	
Compressors	Power Supply	3 Ph / 380 V / 60 Hz	3 Ph / 380 V / 60 Hz	3 Ph / 380 V / 60 Hz	3 Ph / 380 V / 60 Hz	
	Starter Type	Y-DELTA	Y-DELTA	Y-DELTA	Y-DELTA	
	RLA	A	133	178	199	122 / 122
	Starting Current	A	431	506	568	482
	Refrigerant Circuits	EA	1	1	1	2
Evaporator	Inlet/Outlet Temperature	°C	12.22 / 6.67	12.22 / 6.67	12.22 / 6.67	12.22 / 6.67
	Flow Rate	m ³ /h	44.4	53.7	64.19	70.86
	Pressure Drop	mAq	9.45	11.3	11.1	4.78
	Connection	A	100	100	125	125
Condenser	Ambient Temperature	°C	35	35	35	35
	Number	EA	6	6	8	4 / 4
Fans	Fan Motor Input Power	kW	12.6	12.6	16.8	16.8
	Total Chiller Airflow	CMM	1,890	1,890	2,520	2,520
Weight	Shipping Weight	kg	3,000	3,200	3,700	4,500
	Operating Weight	kg	3,151	3,356	3,898	4,710
Dimension	Length	mm	3,020	3,020	4,010	4,010
	Width	mm	2,150	2,150	2,150	2,150
	Height	mm	2,320	2,320	2,320	2,320
Refrigerant	kg	80	90	110	60 / 60	
Oil	L	16	18	23	16 / 16	

Note:
 1. 1usRT = 3,024kcal/hr = 3.517kW, 1mH2O = 9.8kPa
 2. Fouling factor of water in evaporator is 0.0176m²°C/kW
 3. Ambient temperature is 35.00°C, Chilled water temperature outlet is 6.67°C, inlet is 12.22°C.
 4. Due to our policy of innovation some specifications may be changed without prior notification.
 5. All data in this table is rated in accordance with AHRI Standard 550/590.

Specification



RCAW Series (60Hz)

Model		Units	RCAW016CA2C	RCAW018CA2C	RCAW020CA2C	RCAW022CA2C
Unit Capacity	usRT		146	174	195	220
	kW		514	612.4	687.1	775.1
	kcal/h		441,960	526,569	590,800	666,466
Compressors	Power Supply		3 Ph / 380 V / 60 Hz	3 Ph / 380 V / 60 Hz	3 Ph / 380 V / 60 Hz	3 Ph / 380 V / 60 Hz
	Starter Type		Y-DELTA	Y-DELTA	Y-DELTA	Y-DELTA
	RLA	A	137 / 117	155 / 155	177 / 177	204 / 190
	Starting Current	A	548	551	684	758
	Refrigerant Circuits	EA	2	2	2	2
Evaporator	Inlet/Outlet Temperature	°C	12.22 / 6.67	12.22 / 6.67	12.22 / 6.67	12.22 / 6.67
	Flow Rate	m ³ /h	79.39	94.59	106.1	119.7
	Pressure Drop	mAq	4.6	4.9	5.33	5.92
	Connection	A	125	125	125	150
Condenser	Ambient Temperature	°C	35	35	35	35
Fans	Number	EA	6 / 4	6 / 6	6 / 6	8 / 6
	Fan Motor Input Power	kW	21	25.2	25.2	29.4
	Total Chiller Airflow	CMM	3,150	3,780	3,780	4,410
Weight	Shipping Weight	kg	4,900	5,600	5,800	6,100
	Operating Weight	kg	5,127	5,875	6,081	6,402
Dimension	Length	mm	4,990	5,980	5,980	6,970
	Width	mm	2,150	2,150	2,150	2,150
	Height	mm	2,320	2,320	2,320	2,320
Refrigerant	kg	70 / 60	80 / 80	80 / 80	90 / 80	
Oil	L	16 / 16	16 / 16	18 / 18	23 / 20	

Note:
 1. 1usRT = 3,024kcal/hr = 3.517kW, 1mH2O = 9.8kPa
 2. Fouling factor of water in evaporator is 0.0176m²·°C/kW
 3. Ambient temperature is 35.00°C, Chilled water temperature outlet is 6.67°C, inlet is 12.22°C.
 4. Due to our policy of innovation some specifications may be changed without prior notification.
 5. All data in this table is rated in accordance with AHRI Standard 550/590.

Specification



RCAW Series (60Hz)

Model		Units	RCAW024CA2C	RCAW026CA2C	RCAW028CA2C	RCAW030CA2C
Unit Capacity	usRT		233	256	283	304
	kW		821.1	901.2	994.5	1069
	kcal/h		706,019	774,893	855,116	919,175
Compressors	Power Supply		3 Ph / 380 V / 60 Hz	3 Ph / 380 V / 60 Hz	3 Ph / 380 V / 60 Hz	3 Ph / 380 V / 60 Hz
	Starter Type		Y-DELTA	Y-DELTA	Y-DELTA	Y-DELTA
	RLA	A	234 / 194	229 / 210	263 / 227	260 / 260
	Starting Current	A	762	870	1,092	1,124
	Refrigerant Circuits	EA	2	2	2	2
Evaporator	Inlet/Outlet Temperature	°C	12.22 / 6.67	12.22 / 6.67	12.22 / 6.67	12.22 / 6.67
	Flow Rate	m ³ /h	126.8	139.2	153.6	165.2
	Pressure Drop	mAq	5.48	10.4	10.4	9.52
	Connection	A	150	150	150	150
Condenser	Ambient Temperature	°C	35	35	35	35
Fans	Number	EA	8 / 6	8 / 8	10 / 8	10 / 10
	Fan Motor Input Power	kW	29.4	33.6	37.8	42
	Total Chiller Airflow	CMM	4,410	5,040	5,670	6,300
Weight	Shipping Weight	kg	6,400	6,700	7,500	8,100
	Operating Weight	kg	6,742	7,066	7,925	8,548
Dimension	Length	mm	6,970	7,950	8,940	9,920
	Width	mm	2,150	2,150	2,150	2,150
	Height	mm	2,320	2,320	2,320	2,320
Refrigerant	kg	100 / 90	110 / 100	130 / 120	130 / 130	
Oil	L	23 / 20	23 / 20	28 / 23	28 / 28	

Note:
 1. 1usRT = 3,024kcal/hr = 3.517kW, 1mH2O = 9.8kPa
 2. Fouling factor of water in evaporator is 0.0176m²·°C/kW
 3. Ambient temperature is 35.00°C, Chilled water temperature outlet is 6.67°C, inlet is 12.22°C.
 4. Due to our policy of innovation some specifications may be changed without prior notification.
 5. All data in this table is rated in accordance with AHRI Standard 550/590.

Specification



RCAW Series (60Hz)

Model		Units	RCAW036CA3C	RCAW040CA3C	RCAW044CA4C	RCAW048CA4C	RCAW052CA4C
Unit Capacity	usRT		359	396	441	467	512
	kW		1,261	1,393	1,550	1,642	1,802
	kcal/h		1,084,265	1,197,764	1,332,760	1,411,866	1,549,441
Compressors	Power Supply		3 Ph / 380 V / 60 Hz	3 Ph / 380 V / 60 Hz	3 Ph / 380 V / 60 Hz	3 Ph / 380 V / 60 Hz	3 Ph / 380 V / 60 Hz
	Starter Type		Y-DELTA	Y-DELTA	Y-DELTA	Y-DELTA	Y-DELTA
	RLA	A	212 / 212 / 191	232 / 232 / 232	204 / 190 / 204 / 190	234 / 194 / 234 / 194	229 / 210 / 229 / 210
	Starting Current	A	971	1,123	1,151	1,281	1,309
	Refrigerant Circuits	EA	3	3	4	4	4
Evaporator	Inlet/Outlet Temperature	°C	12.22 / 6.67	12.22 / 6.67	12.22 / 6.67	12.22 / 6.67	12.22 / 6.67
	Flow Rate	m ³ /h	194.8	215.1	239.4	253.6	278.4
	Pressure Drop	mAq	12.1	11.9	5.92	5.48	10.4
	Connection	A	200	200	150	150	150
Condenser	Ambient Temperature	°C	35	35	35	35	35
Fans	Number	EA	8 / 8 / 6	8 / 8 / 8	8 / 6 / 8 / 6	8 / 6 / 8 / 6	8 / 8 / 8 / 8
	Fan Motor Input Power	kW	46.2	50.4	58.8	58.8	67.2
	Total Chiller Airflow	CMM	6,930	7,560	8,820	8,820	10,080
Weight	Shipping Weight	kg	9,500	10,000	12,200	12,800	13,400
	Operating Weight	kg	10,074	10,602	12,804	13,484	14,132
Dimension	Length	mm	10,910	11,900	13,930	13,930	15,900
	Width	mm	2,150	2,150	2,150	2,150	2,150
	Height	mm	2,320	2,320	2,320	2,320	2,320
Refrigerant	kg	110 / 110 / 100	110 / 110 / 110	90 / 80 / 90 / 80	100 / 90 / 100 / 90	110 / 100 / 110 / 100	
Oil	L	20 / 20 / 20	23 / 23 / 23	23 / 20 / 23 / 20	23 / 20 / 23 / 20	23 / 20 / 23 / 20	

Note:
 1. 1usRT = 3,024kcal/hr = 3.517kW, 1mH2O = 9.8kPa
 2. Fouling factor of water in evaporator is 0.0176m²·°C/kW
 3. Ambient temperature is 35.00°C, Chilled water temperature outlet is 6.67°C, inlet is 12.22°C.
 4. Due to our policy of innovation some specifications may be changed without prior notification.
 5. All data in this table is rated in accordance with AHRI Standard 550/590.

Specification



RCAW Series (50Hz)

Model		Units	RCAW008CA1C	RCAW010CA1C	RCAW012CA1C	RCAW014CA2C
Unit Capacity	usRT		84	97	111	131
	kW		295.5	341.9	391.5	461
	kcal/h		254,084	293,981	336,629	396,389
Compressors	Power Supply		3 Ph / 380 V / 50 Hz	3 Ph / 380 V / 50 Hz	3 Ph / 380 V / 50 Hz	3 Ph / 380 V / 50 Hz
	Starter Type		Y-DELTA	Y-DELTA	Y-DELTA	Y-DELTA
	RLA	A	141	173	182	120 / 120
	Starting Current	A	320	472	541	483
	Refrigerant Circuits	EA	1	1	1	2
Evaporator	Inlet/Outlet Temperature	°C	12.22 / 6.67	12.22 / 6.67	12.22 / 6.67	12.22 / 6.67
	Flow Rate	m ³ /h	45.64	52.81	60.47	71.21
	Pressure Drop	mAq	9.98	11	9.86	4.83
	Connection	A	100	100	125	125
Condenser	Ambient Temperature	°C	35	35	35	35
Fans	Number	EA	6	6	8	4 / 4
	Fan Motor Input Power	kW	10.8	10.8	14.4	14.4
	Total Chiller Airflow	CMM	1,890	1,890	2,520	2,520
Weight	Shipping Weight	kg	3,200	3,300	3,700	4,700
	Operating Weight	kg	3,353	3,457	3,899	4,912
Dimension	Length	mm	3,020	3,020	4,010	4,010
	Width	mm	2,150	2,150	2,150	2,150
	Height	mm	2,320	2,320	2,320	2,320
Refrigerant	kg	90	90	110	60 / 60	
Oil	L	18	23	23	16 / 16	

Note:
 1. 1usRT = 3,024kcal/hr = 3.517kW, 1mH2O = 9.8kPa
 2. Fouling factor of water in evaporator is 0.0176m²·°C/kW
 3. Ambient temperature is 35.00°C, Chilled water temperature outlet is 6.67°C, inlet is 12.22°C.
 4. Due to our policy of innovation some specifications may be changed without prior notification.
 5. All data in this table is rated in accordance with AHRI Standard 550/590.

Specification



RCAW Series (50Hz)

Model		Units	RCAW016CA2C	RCAW018CA2C	RCAW020CA2C	RCAW022CA2C
Unit Capacity	usRT		154	172	192	211
	kW		541.8	603.7	675.8	743.4
	kcal/h		465,864	519,089	581,083	639,209
Compressors	Power Supply		3 Ph / 380 V / 50 Hz	3 Ph / 380 V / 50 Hz	3 Ph / 380 V / 50 Hz	3 Ph / 380 V / 50 Hz
	Starter Type		Y-DELTA	Y-DELTA	Y-DELTA	Y-DELTA
	RLA	A	159 / 117	155 / 143	173 / 173	187 / 173
	Starting Current	A	552	614	644	654
	Refrigerant Circuits	EA	2	2	2	2
Evaporator	Inlet/Outlet Temperature	°C	12.22 / 6.67	12.22 / 6.67	12.22 / 6.67	12.22 / 6.67
	Flow Rate	m ³ /h	83.69	93.25	104.4	114.8
	Pressure Drop	mAq	5.1	4.76	5.16	5.45
	Connection	A	125	125	125	150
Condenser	Ambient Temperature	°C	35	35	35	35
Fans	Number	EA	6 / 4	6 / 6	6 / 6	8 / 6
	Fan Motor Input Power	kW	18	21.6	21.6	25.2
	Total Chiller Airflow	CMM	3,150	3,780	3,780	4,410
Weight	Shipping Weight	kg	5,200	5,800	5,900	6,300
	Operating Weight	kg	5,431	6,077	6,183	6,602
Dimension	Length	mm	4,990	5,980	5,980	6,970
	Width	mm	2,150	2,150	2,150	2,150
	Height	mm	2,320	2,320	2,320	2,320
Refrigerant	kg	80 / 60	80 / 80	80 / 80	90 / 80	
Oil	L	20 / 16	20 / 18	23 / 23	23 / 20	

Note:
 1. 1usRT = 3,024kcal/hr = 3.517kW, 1mH2O = 9.8kPa
 2. Fouling factor of water in evaporator is 0.0176m²·°C/kW
 3. Ambient temperature is 35.00°C, Chilled water temperature outlet is 6.67°C, inlet is 12.22°C.
 4. Due to our policy of innovation some specifications may be changed without prior notification.
 5. All data in this table is rated in accordance with AHRI Standard 550/590.

Specification



RCAW Series (50Hz)

Model		Units	RCAW024CA2C	RCAW026CA2C	RCAW028CA2C	RCAW030CA2C
Unit Capacity	usRT		226	251	267	302
	kW		794.9	884.4	940.7	1062
	kcal/h		683,491	760,447	808,856	913,156
Compressors	Power Supply		3 Ph / 380 V / 50 Hz	3 Ph / 380 V / 50 Hz	3 Ph / 380 V / 50 Hz	3 Ph / 380 V / 50 Hz
	Starter Type		Y-DELTA	Y-DELTA	Y-DELTA	Y-DELTA
	RLA	A	225 / 178	223 / 223	229 / 218	262 / 262
	Starting Current	A	879	924	1,008	1,094
	Refrigerant Circuits	EA	2	2	2	2
Evaporator	Inlet/Outlet Temperature	°C	12.22 / 6.67	12.22 / 6.67	12.22 / 6.67	12.22 / 6.67
	Flow Rate	m ³ /h	122.8	136.6	145.3	164
	Pressure Drop	mAq	5.14	9.99	9.33	9.38
	Connection	A	150	150	150	150
Condenser	Ambient Temperature	°C	35	35	35	35
Fans	Number	EA	8 / 6	8 / 8	10 / 8	10 / 10
	Fan Motor Input Power	kW	25.2	28.8	32.4	36
	Total Chiller Airflow	CMM	4,410	5,040	5,670	6,300
Weight	Shipping Weight	kg	6,600	7,200	7,900	8,400
	Operating Weight	kg	6,943	7,569	8,328	8,852
Dimension	Length	mm	6,970	7,950	8,940	9,920
	Width	mm	2,150	2,150	2,150	2,150
	Height	mm	2,320	2,320	2,320	2,320
Refrigerant	kg	100 / 90	110 / 110	130 / 120	130 / 130	
Oil	L	28 / 20	28 / 28	28 / 28	28 / 28	

Note:
 1. 1usRT = 3,024kcal/hr = 3.517kW, 1mH2O = 9.8kPa
 2. Fouling factor of water in evaporator is 0.0176m²·°C/kW
 3. Ambient temperature is 35.00°C, Chilled water temperature outlet is 6.67°C, inlet is 12.22°C.
 4. Due to our policy of innovation some specifications may be changed without prior notification.
 5. All data in this table is rated in accordance with AHRI Standard 550/590.

Specification



RCAW Series (50Hz)

Model		Units	RCAW036CA3C	RCAW040CA3C	RCAW044CA4C	RCAW048CA4C	RCAW052CA4C
Unit Capacity	usRT		357	380	423	452	503
	kW		1,255	1,338	1,487	1,590	1,769
	kcal/h		1,079,106	1,150,473	1,278,590	1,367,154	1,521,066
Compressors	Power Supply		3 Ph / 380 V / 50 Hz	3 Ph / 380 V / 50 Hz	3 Ph / 380 V / 50 Hz	3 Ph / 380 V / 50 Hz	3 Ph / 380 V / 50 Hz
	Starter Type		Y-DELTA	Y-DELTA	Y-DELTA	Y-DELTA	Y-DELTA
	RLA	A	225 / 225 / 178	223 / 223 / 223	187 / 173 / 187 / 173	225 / 178 / 225 / 178	223 / 223 / 223 / 223
	Starting Current	A	1,103	1,227	1,075	1,281	1,369
	Refrigerant Circuits	EA	3	3	4	4	4
Evaporator	Inlet/Outlet Temperature	°C	12.22 / 6.67	12.22 / 6.67	12.22 / 6.67	12.22 / 6.67	12.22 / 6.67
	Flow Rate	m ³ /h	193.8	206.6	229.6	245.6	273.2
	Pressure Drop	mAq	12	11	5.45	5.14	9.99
	Connection	A	200	200	150	150	150
Condenser	Ambient Temperature	°C	35	35	35	35	35
Fans	Number	EA	8 / 8 / 6	8 / 8 / 8	8 / 6 / 8 / 6	8 / 6 / 8 / 6	8 / 8 / 8 / 8
	Fan Motor Input Power	kW	39.6	43.2	50.4	50.4	57.6
	Total Chiller Airflow	CMM	6,930	7,560	8,820	8,820	10,080
Weight	Shipping Weight	kg	10,100	10,700	12,600	13,200	14,400
	Operating Weight	kg	10,697	11,305	13,204	13,886	15,138
Dimension	Length	mm	10,910	11,900	13,930	13,930	15,900
	Width	mm	2,150	2,150	2,150	2,150	2,150
	Height	mm	2,320	2,320	2,320	2,320	2,320
Refrigerant	kg	110 / 110 / 110	110 / 110 / 110	90 / 80 / 90 / 80	100 / 90 / 100 / 90	110 / 110 / 110 / 110	
Oil	L	28 / 28 / 20	28 / 28 / 28	23 / 20 / 23 / 20	28 / 20 / 28 / 20	28 / 28 / 28 / 28	

- Note:
- 1 usRT = 3,024kcal/hr = 3.517kW, 1mH2O = 9.8kPa
 2. Fouling factor of water in evaporator is 0.0176m²·°C/kW
 3. Ambient temperature is 35.00°C, Chilled water temperature outlet is 6.67°C, inlet is 12.22°C.
 4. Due to our policy of innovation some specifications may be changed without prior notification.
 5. All data in this table is rated in accordance with AHRI Standard 550/590.

Specification



MCAW Series (60Hz, Standard)

Model		Units	MCAW008CA1B	MCAW010CA1B	MCAW012CA1B	MCAW014CA1B
Unit Capacity	usRT		80	102	116	135
	kW		280.4	357.1	406.2	475.5
	kcal/h		241,101	307,051	349,269	408,856
Compressors	Power Supply		3 Ph / 380 V / 60 Hz	3 Ph / 380 V / 60 Hz	3 Ph / 380 V / 60 Hz	3 Ph / 380 V / 60 Hz
	Starter Type		Y-DELTA	Y-DELTA	Y-DELTA	Y-DELTA
	RLA	A	141	191	186	245
	Starting Current	A	396	560	568	856
	Refrigerant Circuits	EA	1	1	1	1
Evaporator	Inlet/Outlet Temperature	°C	12.22 / 6.67	12.22 / 6.67	12.22 / 6.67	12.22 / 6.67
	Flow Rate	m ³ /h	43.31	55.15	62.74	73.44
	Pressure Drop	mAq	9.62	13.3	11.1	5.89
	Connection	A	100	100	125	125
Condenser	Ambient Temperature	°C	35	35	35	35
Fans	Number	EA	6	6	8	8
	Fan Motor Input Power	kW	12.6	12.6	16.8	16.8
	Total Chiller Airflow	CMM	1,890	1,890	2,520	2,520
Weight	Shipping Weight	kg	3,100	3,300	3,600	4,000
	Operating Weight	kg	3,269	3,475	3,795	4,244
Dimension	Length	mm	3,020	3,020	4,010	4,010
	Width	mm	2,150	2,150	2,150	2,150
	Height	mm	2,320	2,320	2,320	2,320
Refrigerant	kg	90	100	100	140	
Oil	L	16	23	20	28	

- Note:
- 1 usRT = 3,024kcal/hr = 3.517kW, 1mH2O = 9.8kPa
 2. Fouling factor of water in evaporator is 0.0176m²·°C/kW
 3. Ambient temperature is 35.00°C, Chilled water temperature outlet is 6.67°C, inlet is 12.22°C.
 4. Due to our policy of innovation some specifications may be changed without prior notification.
 5. All data in this table is rated in accordance with AHRI Standard 550/590.

Specification



MCAW Series (60Hz, Standard)

Model		Units	MCAW014CA2B	MCAW016CA1B	MCAW016CA2B	MCAW018CA2B
Unit Capacity	usRT		141	162	164	179
	kW		496.4	571.3	575.2	628.4
	kcal/h		426,827	491,230	494,583	540,327
Compressors	Power Supply		3 Ph / 380 V / 60 Hz	3 Ph / 380 V / 60 Hz	3 Ph / 380 V / 60 Hz	3 Ph / 380 V / 60 Hz
	Starter Type		Y-DELTA	Y-DELTA	Y-DELTA	Y-DELTA
	RLA	A	132 / 132	290	162 / 148	157 / 157
	Starting Current	A	555	1,108	654	663
	Refrigerant Circuits	EA	2	1	2	2
Evaporator	Inlet/Outlet Temperature	°C	12.22 / 6.67	12.22 / 6.67	12.22 / 6.67	12.22 / 6.67
	Flow Rate	m ³ /h	76.68	88.24	88.84	97.05
	Pressure Drop	mAq	6.7	6.68	7.08	7.05
	Connection	A	125	125	125	125
Condenser	Ambient Temperature	°C	35	35	35	35
Fans	Number	EA	4 / 4	10 / 4	6 / 4	6 / 6
	Fan Motor Input Power	kW	16.8	21	21	25.2
	Total Chiller Airflow	CMM	2,520	3,150	3,150	3,780
Weight	Shipping Weight	kg	4,700	4,500	5,300	5,700
	Operating Weight	kg	4,951	4,761	5,570	5,985
Dimension	Length	mm	4,010	4,990	4,990	5,980
	Width	mm	2,150	2,150	2,150	2,150
	Height	mm	2,320	2,320	2,320	2,320
Refrigerant	kg	70 / 70	150	90 / 80	80 / 80	
Oil	L	16 / 16	28	18 / 16	18 / 18	

Note:
 1. 1usRT = 3,024kcal/hr = 3.517kW, 1mH2O = 9.8kPa
 2. Fouling factor of water in evaporator is 0.0176m²·°C/kW
 3. Ambient temperature is 35.00°C, Chilled water temperature outlet is 6.67°C, inlet is 12.22°C.
 4. Due to our policy of innovation some specifications may be changed without prior notification.
 5. All data in this table is rated in accordance with AHRI Standard 550/590.

Specification



MCAW Series (60Hz, Standard)

Model		Units	MCAW020CA2B	MCAW022CA2B	MCAW024CA2B	MCAW026CA2B	MCAW028CA2B
Unit Capacity	usRT		200	219	234	263	282
	kW		704	769.1	823.6	925.6	990
	kcal/h		605,331	661,307	708,169	795,873	851,247
Compressors	Power Supply		3 Ph / 380 V / 60 Hz	3 Ph / 380 V / 60 Hz	3 Ph / 380 V / 60 Hz	3 Ph / 380 V / 60 Hz	3 Ph / 380 V / 60 Hz
	Starter Type		Y-DELTA	Y-DELTA	Y-DELTA	Y-DELTA	Y-DELTA
	RLA	A	188 / 176	190 / 185	211 / 211	245 / 245	255 / 241
	Starting Current	A	735	752	870	1,101	1,240
	Refrigerant Circuits	EA	2	2	2	2	2
Evaporator	Inlet/Outlet Temperature	°C	12.22 / 6.67	12.22 / 6.67	12.22 / 6.67	12.22 / 6.67	12.22 / 6.67
	Flow Rate	m ³ /h	108.7	118.8	127.2	143	152.9
	Pressure Drop	mAq	7.27	7.68	7.05	13.4	13
	Connection	A	125	150	150	150	150
Condenser	Ambient Temperature	°C	35	35	35	35	35
Fans	Number	EA	6 / 6	8 / 6	8 / 6	8 / 8	10 / 8
	Fan Motor Input Power	kW	25.2	29.4	29.4	33.6	37.8
	Total Chiller Airflow	CMM	3,780	4,410	4,410	5,040	5,670
Weight	Shipping Weight	kg	5,700	6,100	6,400	7,100	7,700
	Operating Weight	kg	5,993	6,412	6,753	7,464	8,118
Dimension	Length	mm	5,980	6,970	6,970	7,950	8,940
	Width	mm	2,150	2,150	2,150	2,150	2,150
	Height	mm	2,320	2,320	2,320	2,320	2,320
Refrigerant	kg	90 / 80	90 / 80	100 / 90	110 / 110	130 / 120	
Oil	L	23 / 20	20 / 23	23 / 23	28 / 28	28 / 28	

Note:
 1. 1usRT = 3,024kcal/hr = 3.517kW, 1mH2O = 9.8kPa
 2. Fouling factor of water in evaporator is 0.0176m²·°C/kW
 3. Ambient temperature is 35.00°C, Chilled water temperature outlet is 6.67°C, inlet is 12.22°C.
 4. Due to our policy of innovation some specifications may be changed without prior notification.
 5. All data in this table is rated in accordance with AHRI Standard 550/590.

MCAW Series (60Hz, Standard)

Model		Units	MCAW030CA2B	MCAW036CA3B	MCAW040CA3B	MCAW045CA4B	MCAW050CA4B
Unit Capacity	usRT		303	348	396	445	497
	kW		1,065	1,223	1,392	1,564	1,748
	kcal/h		915,735	1,051,591	1,196,905	1,344,798	1,503,009
Compressors	Power Supply		3 Ph / 380 V / 60 Hz	3 Ph / 380 V / 60 Hz	3 Ph / 380 V / 60 Hz	3 Ph / 380 V / 60 Hz	3 Ph / 380 V / 60 Hz
	Starter Type		Y-DELTA	Y-DELTA	Y-DELTA	Y-DELTA	Y-DELTA
	RLA	A	295 / 260	210 / 210 / 210	246 / 246 / 246	209 / 193 / 209 / 193	241 / 208 / 241 / 208
	Starting Current	A	1,368	1,079	1,349	1,254	1,514
	Refrigerant Circuits	EA	2	3	3	4	4
Evaporator	Inlet/Outlet Temperature	°C	12.22 / 6.67	12.22 / 6.67	12.22 / 6.67	12.22 / 6.67	12.22 / 6.67
	Flow Rate	m ³ /h	164.5	188.8	214.9	241.5	270.1
	Pressure Drop	mAq	14.2	15.6	16	5.96	11.2
	Connection	A	150	200	200	150	150
Condenser	Ambient Temperature	°C	35	35	35	35	35
Fans	Number	EA	10 / 8	8 / 8 / 6	8 / 8 / 8	8 / 6 / 8 / 6	8 / 8 / 8 / 8
	Fan Motor Input Power	kW	37.8	46.2	50.4	58.8	67.2
	Total Chiller Airflow	CMM	5,670	6,930	7,560	8,820	10,080
Weight	Shipping Weight	kg	7,900	9,400	10,500	12,600	13,800
	Operating Weight	kg	8,323	9,941	11,117	13,304	14,524
Dimension	Length	mm	8,940	10,910	11,900	13,930	15,900
	Width	mm	2,150	2,150	2,150	2,150	2,150
	Height	mm	2,320	2,320	2,320	2,320	2,320
Refrigerant	kg	130 / 120	100 / 100 / 90	110 / 110 / 110	100 / 90 / 100 / 90	110 / 100 / 110 / 100	
Oil	L	28 / 28	23 / 23 / 23	28 / 28 / 28	23 / 20 / 23 / 20	28 / 23 / 28 / 23	

Note:
 1. 1usRT = 3,024kcal/hr = 3.517kW, 1mH2O = 9.8kPa
 2. Fouling factor of water in evaporator is 0.0176m²·°C/kW
 3. Ambient temperature is 35.00°C, Chilled water temperature outlet is 6.67°C, inlet is 12.22°C.
 4. Due to our policy of innovation some specifications may be changed without prior notification.
 5. All data in this table is rated in accordance with AHRI Standard 550/590.

MCAW Series (60Hz, High)

Model		Units	MCAW008CA1B	MCAW010CA1B	MCAW012CA1B	MCAW014CA1B
Unit Capacity	usRT		78	103	121	136
	kW		273.1	361	425.9	480
	kcal/h		234,824	310,404	366,208	412,726
Compressors	Power Supply		3 Ph / 380 V / 60 Hz	3 Ph / 380 V / 60 Hz	3 Ph / 380 V / 60 Hz	3 Ph / 380 V / 60 Hz
	Starter Type		Y-DELTA	Y-DELTA	Y-DELTA	Y-DELTA
	RLA	A	121	178	198	231
	Starting Current	A	431	506	568	659
	Refrigerant Circuits	EA	1	1	1	1
Evaporator	Inlet/Outlet Temperature	°C	12.22 / 6.67	12.22 / 6.67	12.22 / 6.67	12.22 / 6.67
	Flow Rate	m ³ /h	42.18	55.76	65.79	74.13
	Pressure Drop	mAq	9.13	13.6	12.2	6
	Connection	A	100	100	125	125
Condenser	Ambient Temperature	°C	35	35	35	35
Fans	Number	EA	6	6	8	8
	Fan Motor Input Power	kW	12.6	12.6	16.8	16.8
	Total Chiller Airflow	CMM	1,890	1,890	2,520	2,520
Weight	Shipping Weight	kg	3,100	3,300	3,700	3,900
	Operating Weight	kg	3,267	3,473	3,896	4,142
Dimension	Length	mm	3,020	3,020	4,010	4,010
	Width	mm	2,150	2,150	2,150	2,150
	Height	mm	2,320	2,320	2,320	2,320
Refrigerant	kg	90	90	100	140	
Oil	L	16	18	23	23	

Note:
 1. 1usRT = 3,024kcal/hr = 3.517kW, 1mH2O = 9.8kPa
 2. Fouling factor of water in evaporator is 0.0176m²·°C/kW
 3. Ambient temperature is 35.00°C, Chilled water temperature outlet is 6.67°C, inlet is 12.22°C.
 4. Due to our policy of innovation some specifications may be changed without prior notification.
 5. All data in this table is rated in accordance with AHRI Standard 550/590.

Specification



MCAW Series (60Hz, High)

Model		Units	MCAW014CA2B	MCAW016CA1B	MCAW016CA2B	MCAW018CA2B
Unit Capacity	usRT		137	158	158	182
	kW		480.9	555.2	556.4	641.4
	kcal/h		413,500	477,386	478,418	551,505
Compressors	Power Supply		3 Ph / 380 V / 60 Hz	3 Ph / 380 V / 60 Hz	3 Ph / 380 V / 60 Hz	3 Ph / 380 V / 60 Hz
	Starter Type		Y-DELTA	Y-DELTA	Y-DELTA	Y-DELTA
	RLA	A	122 / 122	259	139 / 129	155 / 155
	Starting Current	A	482	864	560	551
	Refrigerant Circuits	EA	2	1	2	2
Evaporator	Inlet/Outlet Temperature	°C	12.22 / 6.67	12.22 / 6.67	12.22 / 6.67	12.22 / 6.67
	Flow Rate	m ³ /h	74.27	85.76	85.94	99.06
	Pressure Drop	mAq	6.29	6.31	6.62	7.34
	Connection	A	125	125	125	125
Condenser	Ambient Temperature	°C	35	35	35	35
Fans	Number	EA	4 / 4	10 / 4	6 / 4	6 / 6
	Fan Motor Input Power	kW	16.8	21	21	25.2
	Total Chiller Airflow	CMM	2,520	3,150	3,150	3,780
Weight	Shipping Weight	kg	4,700	4,500	5,400	5,800
	Operating Weight	kg	4,947	4,758	5,665	6,083
Dimension	Length	mm	4,010	4,990	4,990	5,980
	Width	mm	2,150	2,150	2,150	2,150
	Height	mm	2,320	2,320	2,320	2,320
Refrigerant	kg	70 / 70	150	80 / 70	80 / 80	
Oil	L	16 / 16	28	16 / 16	16 / 16	

Note:
 1. 1usRT = 3,024kcal/hr = 3.517kW, 1mH2O = 9.8kPa
 2. Fouling factor of water in evaporator is 0.0176m²·°C/kW
 3. Ambient temperature is 35.00°C, Chilled water temperature outlet is 6.67°C, inlet is 12.22°C.
 4. Due to our policy of innovation some specifications may be changed without prior notification.
 5. All data in this table is rated in accordance with AHRI Standard 550/590.

Specification



MCAW Series (60Hz, High)

Model		Units	MCAW020CA2B	MCAW022CA2B	MCAW024CA2B	MCAW026CA2B	MCAW028CA2B
Unit Capacity	usRT		205	222	241	266	281
	kW		720.5	779.6	846.6	935.8	988.8
	kcal/h		619,518	670,335	727,945	804,643	850,215
Compressors	Power Supply		3 Ph / 380 V / 60 Hz	3 Ph / 380 V / 60 Hz	3 Ph / 380 V / 60 Hz	3 Ph / 380 V / 60 Hz	3 Ph / 380 V / 60 Hz
	Starter Type		Y-DELTA	Y-DELTA	Y-DELTA	Y-DELTA	Y-DELTA
	RLA	A	177 / 177	187 / 187	207 / 207	228 / 210	263 / 227
	Starting Current	A	684	755	775	869	1,091
	Refrigerant Circuits	EA	2	2	2	2	2
Evaporator	Inlet/Outlet Temperature	°C	12.22 / 6.67	12.22 / 6.67	12.22 / 6.67	12.22 / 6.67	12.22 / 6.67
	Flow Rate	m ³ /h	111.3	120.4	130.8	144.5	152.7
	Pressure Drop	mAq	7.61	7.89	7.45	13.7	12.9
	Connection	A	125	150	150	150	150
Condenser	Ambient Temperature	°C	35	35	35	35	35
Fans	Number	EA	6 / 6	8 / 6	8 / 6	8 / 8	10 / 8
	Fan Motor Input Power	kW	25.2	29.4	29.4	33.6	37.8
	Total Chiller Airflow	CMM	3,780	4,410	4,410	5,040	5,670
Weight	Shipping Weight	kg	5,900	6,300	6,600	6,900	7,700
	Operating Weight	kg	6,190	6,611	6,951	7,258	8,115
Dimension	Length	mm	5,980	6,970	6,970	7,950	8,940
	Width	mm	2,150	2,150	2,150	2,150	2,150
	Height	mm	2,320	2,320	2,320	2,320	2,320
Refrigerant	kg	80 / 80	90 / 80	100 / 90	100 / 100	130 / 120	
Oil	L	18 / 18	20 / 20	23 / 23	23 / 20	28 / 23	

Note:
 1. 1usRT = 3,024kcal/hr = 3.517kW, 1mH2O = 9.8kPa
 2. Fouling factor of water in evaporator is 0.0176m²·°C/kW
 3. Ambient temperature is 35.00°C, Chilled water temperature outlet is 6.67°C, inlet is 12.22°C.
 4. Due to our policy of innovation some specifications may be changed without prior notification.
 5. All data in this table is rated in accordance with AHRI Standard 550/590.

Specification



MCAW Series (60Hz, High)

Model		Units	MCAW030CA2B	MCAW036CA3B	MCAW040CA3B	MCAW045CA4B	MCAW050CA4B
Unit Capacity	usRT		302	360	401	456	500
	kW		1,062	1,267	1,409	1,604	1,757
	kcal/h		913,156	1,089,424	1,211,522	1,379,192	1,510,748
Compressors	Power Supply		3 Ph / 380 V / 60 Hz	3 Ph / 380 V / 60 Hz	3 Ph / 380 V / 60 Hz	3 Ph / 380 V / 60 Hz	3 Ph / 380 V / 60 Hz
	Starter Type		Y-DELTA	Y-DELTA	Y-DELTA	Y-DELTA	Y-DELTA
	RLA	A	269 / 269	205 / 205 / 205	231 / 231 / 231	204 / 190 / 204 / 190	206 / 200 / 206 / 200
	Starting Current	A	1,133	977	1,122	1,152	1,175
	Refrigerant Circuits	EA	2	3	3	4	4
Evaporator	Inlet/Outlet Temperature	°C	12.22 / 6.67	12.22 / 6.67	12.22 / 6.67	12.22 / 6.67	12.22 / 6.67
	Flow Rate	m ³ /h	164	195.7	217.6	247.8	271.3
	Pressure Drop	mAq	14.1	16.7	16.4	6.27	11.3
	Connection	A	150	200	200	150	150
Condenser	Ambient Temperature	°C	35	35	35	35	35
Fans	Number	EA	10 / 8	8 / 8 / 6	8 / 8 / 8	8 / 6 / 8 / 6	8 / 8 / 8 / 8
	Fan Motor Input Power	kW	37.8	46.2	50.4	58.8	67.2
	Total Chiller Airflow	CMM	5,670	6,930	7,560	8,820	10,080
Weight	Shipping Weight	kg	7,900	9,600	10,200	13,000	13,800
	Operating Weight	kg	8,318	10,137	10,814	13,702	14,514
Dimension	Length	mm	8,940	10,910	11,900	13,930	15,900
	Width	mm	2,150	2,150	2,150	2,150	2,150
	Height	mm	2,320	2,320	2,320	2,320	2,320
Refrigerant	kg	130 / 120	100 / 100 / 90	110 / 110 / 110	100 / 90 / 100 / 90	100 / 100 / 100 / 100	
Oil	L	28 / 28	23 / 23 / 23	23 / 23 / 23	23 / 20 / 23 / 20	20 / 23 / 20 / 23	

Note:
 1. 1usRT = 3,024kcal/hr = 3.517kW, 1mH2O = 9.8kPa
 2. Fouling factor of water in evaporator is 0.0176m²·°C/kW
 3. Ambient temperature is 35.00°C, Chilled water temperature outlet is 6.67°C, inlet is 12.22°C.
 4. Due to our policy of innovation some specifications may be changed without prior notification.
 5. All data in this table is rated in accordance with AHRI Standard 550/590.

Specification



MCAW Series (50Hz, Standard)

Model		Units	MCAW008CA1B	MCAW010CA1B	MCAW012CA1B	MCAW014CA1B
Unit Capacity	usRT		82	97	114	134
	kW		287.4	339.4	401	471.9
	kcal/h		247,120	291,831	344,798	405,761
Compressors	Power Supply		3 Ph / 380 V / 50 Hz	3 Ph / 380 V / 50 Hz	3 Ph / 380 V / 50 Hz	3 Ph / 380 V / 50 Hz
	Starter Type		Y-DELTA	Y-DELTA	Y-DELTA	Y-DELTA
	RLA	A	142	175	198	248
	Starting Current	A	472	532	701	823
	Refrigerant Circuits	EA	1	1	1	1
Evaporator	Inlet/Outlet Temperature	°C	12.22 / 6.67	12.22 / 6.67	12.22 / 6.67	12.22 / 6.67
	Flow Rate	m ³ /h	44.39	52.43	61.94	72.88
	Pressure Drop	mAq	10.1	12	10.8	5.8
	Connection	A	100	100	125	125
Condenser	Ambient Temperature	°C	35	35	35	35
Fans	Number	EA	6	6	8	8
	Fan Motor Input Power	kW	10.8	10.8	14.4	14.4
	Total Chiller Airflow	CMM	1,890	1,890	2,520	2,520
Weight	Shipping Weight	kg	3,200	3,300	3,800	4,200
	Operating Weight	kg	3,371	3,476	3,998	4,446
Dimension	Length	mm	3,020	3,020	4,010	4,010
	Width	mm	2,150	2,150	2,150	2,150
	Height	mm	2,320	2,320	2,320	2,320
Refrigerant	kg	100	100	100	140	
Oil	L	20	23	28	28	

Note:
 1. 1usRT = 3,024kcal/hr = 3.517kW, 1mH2O = 9.8kPa
 2. Fouling factor of water in evaporator is 0.0176m²·°C/kW
 3. Ambient temperature is 35.00°C, Chilled water temperature outlet is 6.67°C, inlet is 12.22°C.
 4. Due to our policy of innovation some specifications may be changed without prior notification.
 5. All data in this table is rated in accordance with AHRI Standard 550/590.

Specification



MCAW Series (50Hz, Standard)

Model		Units	MCAW014CA2B	MCAW016CA1B	MCAW016CA2B	MCAW018CA2B
Unit Capacity	usRT		142	159	153	182
	kW		500.5	558.3	536.7	638.5
	kcal/h		430,353	480,052	461,479	549,011
Compressors	Power Supply		3 Ph / 380 V / 50 Hz	3 Ph / 380 V / 50 Hz	3 Ph / 380 V / 50 Hz	3 Ph / 380 V / 50 Hz
	Starter Type		Y-DELTA	Y-DELTA	Y-DELTA	Y-DELTA
	RLA	A	141 / 141	274	146 / 134	160 / 155
	Starting Current	A	566	922	606	627
	Refrigerant Circuits	EA	2	1	2	2
Evaporator	Inlet/Outlet Temperature	°C	12.22 / 6.67	12.22 / 6.67	12.22 / 6.67	12.22 / 6.67
	Flow Rate	m ³ /h	77.3	86.24	82.9	98.62
	Pressure Drop	mAq	6.81	6.38	6.17	7.28
	Connection	A	125	125	125	125
Condenser	Ambient Temperature	°C	35	35	35	35
Fans	Number	EA	4 / 4	10 / 4	6 / 4	6 / 6
	Fan Motor Input Power	kW	14.4	18	18	21.6
	Total Chiller Airflow	CMM	2,520	3,150	3,150	3,780
Weight	Shipping Weight	kg	5,000	4,600	5,300	5,800
	Operating Weight	kg	5,255	4,861	5,571	6,087
Dimension	Length	mm	4,010	4,990	4,990	5,980
	Width	mm	2,150	2,150	2,150	2,150
	Height	mm	2,320	2,320	2,320	2,320
Refrigerant	kg	80 / 80	150	90 / 80	90 / 90	
Oil	L	18 / 18	28	20 / 18	20 / 23	

Note:
 1. 1usRT = 3,024kcal/hr = 3.517kW, 1mH2O = 9.8kPa
 2. Fouling factor of water in evaporator is 0.0176m²·°C/kW
 3. Ambient temperature is 35.00°C, Chilled water temperature outlet is 6.67°C, inlet is 12.22°C.
 4. Due to our policy of innovation some specifications may be changed without prior notification.
 5. All data in this table is rated in accordance with AHRI Standard 550/590.

Specification



MCAW Series (50Hz, Standard)

Model		Units	MCAW020CA2B	MCAW022CA2B	MCAW024CA2B	MCAW026CA2B	MCAW028CA2B
Unit Capacity	usRT		203	221	244	259	285
	kW		712.2	777	858.9	912.4	1,004
	kcal/h		612,382	668,100	738,521	784,523	863,285
Compressors	Power Supply		3 Ph / 380 V / 50 Hz	3 Ph / 380 V / 50 Hz	3 Ph / 380 V / 50 Hz	3 Ph / 380 V / 50 Hz	3 Ph / 380 V / 50 Hz
	Starter Type		Y-DELTA	Y-DELTA	Y-DELTA	Y-DELTA	Y-DELTA
	RLA	A	208 / 178	203 / 203	220 / 220	248 / 248	276 / 246
	Starting Current	A	869	904	1,001	1,071	1,168
	Refrigerant Circuits	EA	2	2	2	2	2
Evaporator	Inlet/Outlet Temperature	°C	12.22 / 6.67	12.22 / 6.67	12.22 / 6.67	12.22 / 6.67	12.22 / 6.67
	Flow Rate	m ³ /h	110	120	132.7	140.9	155.1
	Pressure Drop	mAq	7.44	7.84	7.67	13	13.3
	Connection	A	125	150	150	150	150
Condenser	Ambient Temperature	°C	35	35	35	35	35
Fans	Number	EA	6 / 6	8 / 6	8 / 6	8 / 8	10 / 8
	Fan Motor Input Power	kW	21.6	25.2	25.2	28.8	32.4
	Total Chiller Airflow	CMM	3,780	4,410	4,410	5,040	5,670
Weight	Shipping Weight	kg	6,100	6,700	7,100	7,400	7,900
	Operating Weight	kg	6,397	7,018	7,460	7,766	8,320
Dimension	Length	mm	5,980	6,970	6,970	7,950	8,940
	Width	mm	2,150	2,150	2,150	2,150	2,150
	Height	mm	2,320	2,320	2,320	2,320	2,320
Refrigerant	kg	90 / 90	100 / 90	110 / 100	110 / 110	130 / 120	
Oil	L	28 / 23	28 / 28	28 / 28	28 / 28	28 / 28	

Note:
 1. 1usRT = 3,024kcal/hr = 3.517kW, 1mH2O = 9.8kPa
 2. Fouling factor of water in evaporator is 0.0176m²·°C/kW
 3. Ambient temperature is 35.00°C, Chilled water temperature outlet is 6.67°C, inlet is 12.22°C.
 4. Due to our policy of innovation some specifications may be changed without prior notification.
 5. All data in this table is rated in accordance with AHRI Standard 550/590.

MCAW Series (50Hz, Standard)

Model		Units	MCAW030CA2B	MCAW036CA3B	MCAW040CA3B	MCAW045CA4B	MCAW050CA4B
Unit Capacity	usRT		302	354	393	459	509
	kW		1,062	1,246	1,383	1,615	1,791
	kcal/h		913,156	1,071,367	1,189,166	1,388,650	1,539,983
Compressors	Power Supply		3 Ph / 380 V / 50 Hz	3 Ph / 380 V / 50 Hz	3 Ph / 380 V / 50 Hz	3 Ph / 380 V / 50 Hz	3 Ph / 380 V / 50 Hz
	Starter Type		Y-DELTA	Y-DELTA	Y-DELTA	Y-DELTA	Y-DELTA
	RLA	A	281 / 281	206 / 217 / 217	249 / 249 / 249	217 / 206 / 217 / 206	246 / 215 / 246 / 215
	Starting Current	A	1,203	1,135	1,321	1,411	1,499
	Refrigerant Circuits	EA	2	3	3	4	4
Evaporator	Inlet/Outlet Temperature	°C	12.22 / 6.67	12.22 / 6.67	12.22 / 6.67	12.22 / 6.67	12.22 / 6.67
	Flow Rate	m ³ /h	164	192.5	213.5	249.4	276.6
	Pressure Drop	mAq	14.1	16.2	15.8	6.35	11.7
	Connection	A	150	200	200	150	150
Condenser	Ambient Temperature	°C	35	35	35	35	35
Fans	Number	EA	10 / 8	8 / 8 / 6	8 / 8 / 8	8 / 6 / 8 / 6	8 / 8 / 8 / 8
	Fan Motor Input Power	kW	32.4	39.6	43.2	50.4	57.6
	Total Chiller Airflow	CMM	5,670	6,930	7,560	8,820	10,080
Weight	Shipping Weight	kg	7,900	10,300	11,000	13,800	14,800
	Operating Weight	kg	8,323	10,848	11,623	14,516	15,532
Dimension	Length	mm	8,940	10,910	11,900	13,930	15,900
	Width	mm	2,150	2,150	2,150	2,150	2,150
	Height	mm	2,320	2,320	2,320	2,320	2,320
Refrigerant	kg	130 / 120	110 / 110 / 90	120 / 120 / 120	110 / 100 / 110 / 100	110 / 110 / 110 / 110	
Oil	L	28 / 28	28 / 28 / 28	28 / 28 / 28	28 / 28 / 28 / 28	28 / 28 / 28 / 28	

Note:
 1. 1usRT = 3,024kcal/hr = 3.517kW, 1mH2O = 9.8kPa
 2. Fouling factor of water in evaporator is 0.0176m²·°C/kW
 3. Ambient temperature is 35.00°C, Chilled water temperature outlet is 6.67°C, inlet is 12.22°C.
 4. Due to our policy of innovation some specifications may be changed without prior notification.
 5. All data in this table is rated in accordance with AHRI Standard 550/590.

MCAW Series (50Hz, High)

Model		Units	MCAW008CA1B	MCAW010CA1B	MCAW012CA1B	MCAW014CA1B
Unit Capacity	usRT		78	101	116	131
	kW		274.5	355.1	408.5	460.6
	kcal/h		236,028	305,331	351,247	396,045
Compressors	Power Supply		3 Ph / 380 V / 50 Hz	3 Ph / 380 V / 50 Hz	3 Ph / 380 V / 50 Hz	3 Ph / 380 V / 50 Hz
	Starter Type		Y-DELTA	Y-DELTA	Y-DELTA	Y-DELTA
	RLA	A	126	173	182	222
	Starting Current	A	320	472	541	701
	Refrigerant Circuits	EA	1	1	1	1
Evaporator	Inlet/Outlet Temperature	°C	12.22 / 6.67	12.22 / 6.67	12.22 / 6.67	12.22 / 6.67
	Flow Rate	m ³ /h	42.4	54.84	63.09	71.14
	Pressure Drop	mAq	9.23	13.2	11.2	5.53
	Connection	A	100	100	125	125
Condenser	Ambient Temperature	°C	35	35	35	35
Fans	Number	EA	6	6	8	8
	Fan Motor Input Power	kW	10.8	10.8	14.4	14.4
	Total Chiller Airflow	CMM	1,890	1,890	2,520	2,520
Weight	Shipping Weight	kg	3,200	3,400	3,700	4,200
	Operating Weight	kg	3,369	3,575	3,897	4,444
Dimension	Length	mm	3,020	3,020	4,010	4,010
	Width	mm	2,150	2,150	2,150	2,150
	Height	mm	2,320	2,320	2,320	2,320
Refrigerant	kg	90	100	100	140	
Oil	L	16	23	23	28	

Note:
 1. 1usRT = 3,024kcal/hr = 3.517kW, 1mH2O = 9.8kPa
 2. Fouling factor of water in evaporator is 0.0176m²·°C/kW
 3. Ambient temperature is 35.00°C, Chilled water temperature outlet is 6.67°C, inlet is 12.22°C.
 4. Due to our policy of innovation some specifications may be changed without prior notification.
 5. All data in this table is rated in accordance with AHRI Standard 550/590.

MCAW Series (50Hz, High)

Model		Units	MCAW014CA2B	MCAW016CA1B	MCAW016CA2B	MCAW018CA2B
Unit Capacity	usRT		138	157	161	180
	kW		483.7	550.7	565.7	631.9
	kcal/h		415,907	473,517	486,414	543,336
Compressors	Power Supply		3 Ph / 380 V / 50 Hz	3 Ph / 380 V / 50 Hz	3 Ph / 380 V / 50 Hz	3 Ph / 380 V / 50 Hz
	Starter Type		Y-DELTA	Y-DELTA	Y-DELTA	Y-DELTA
	RLA	A	120 / 120	261	146 / 134	155 / 143
	Starting Current	A	483	832	569	614
	Refrigerant Circuits	EA	2	1	2	2
Evaporator	Inlet/Outlet Temperature	°C	12.22 / 6.67	12.22 / 6.67	12.22 / 6.67	12.22 / 6.67
	Flow Rate	m ³ /h	74.71	85.06	87.37	97.6
	Pressure Drop	mAq	6.37	6.21	6.85	7.13
	Connection	A	125	125	125	125
Condenser	Ambient Temperature	°C	35	35	35	35
Fans	Number	EA	4 / 4	10 / 4	6 / 4	6 / 6
	Fan Motor Input Power	kW	14.4	18	18	21.6
	Total Chiller Airflow	CMM	2,520	3,150	3,150	3,780
Weight	Shipping Weight	kg	4,900	4,700	5,600	6,000
	Operating Weight	kg	5,151	4,961	5,870	6,286
Dimension	Length	mm	4,010	4,990	4,990	5,980
	Width	mm	2,150	2,150	2,150	2,150
	Height	mm	2,320	2,320	2,320	2,320
Refrigerant	kg	70 / 70	150	90 / 80	90 / 80	
Oil	L	16 / 16	28	18 / 16	20 / 18	

Note:
 1. 1usRT = 3,024kcal/hr = 3.517kW, 1mH2O = 9.8kPa
 2. Fouling factor of water in evaporator is 0.0176m²·°C/kW
 3. Ambient temperature is 35.00°C, Chilled water temperature outlet is 6.67°C, inlet is 12.22°C.
 4. Due to our policy of innovation some specifications may be changed without prior notification.
 5. All data in this table is rated in accordance with AHRI Standard 550/590.

MCAW Series (50Hz, High)

Model		Units	MCAW020CA2B	MCAW022CA2B	MCAW024CA2B	MCAW026CA2B	MCAW028CA2B
Unit Capacity	usRT		201	216	242	261	278
	kW		708.2	760.3	849.5	918.7	977.4
	kcal/h		608,942	653,740	730,439	789,940	840,413
Compressors	Power Supply		3 Ph / 380 V / 50 Hz	3 Ph / 380 V / 50 Hz	3 Ph / 380 V / 50 Hz	3 Ph / 380 V / 50 Hz	3 Ph / 380 V / 50 Hz
	Starter Type		Y-DELTA	Y-DELTA	Y-DELTA	Y-DELTA	Y-DELTA
	RLA	A	173 / 173	172 / 172	227 / 194	222 / 222	228 / 217
	Starting Current	A	644	653	895	923	1,008
	Refrigerant Circuits	EA	2	2	2	2	2
Evaporator	Inlet/Outlet Temperature	°C	12.22 / 6.67	12.22 / 6.67	12.22 / 6.67	12.22 / 6.67	12.22 / 6.67
	Flow Rate	m ³ /h	109.4	117.4	131.2	141.9	151
	Pressure Drop	mAq	7.35	7.51	7.5	13.2	12.6
	Connection	A	125	150	150	150	150
Condenser	Ambient Temperature	°C	35	35	35	35	35
Fans	Number	EA	6 / 6	8 / 6	8 / 6	8 / 8	10 / 8
	Fan Motor Input Power	kW	21.6	25.2	25.2	28.8	32.4
	Total Chiller Airflow	CMM	3,780	4,410	4,410	5,040	5,670
Weight	Shipping Weight	kg	6,000	6,400	6,900	7,300	8,000
	Operating Weight	kg	6,294	6,712	7,254	7,664	8,418
Dimension	Length	mm	5,980	6,970	6,970	7,950	8,940
	Width	mm	2,150	2,150	2,150	2,150	2,150
	Height	mm	2,320	2,320	2,320	2,320	2,320
Refrigerant	kg	90 / 90	90 / 80	110 / 90	110 / 110	130 / 120	
Oil	L	23 / 23	20 / 20	28 / 23	28 / 28	28 / 28	

Note:
 1. 1usRT = 3,024kcal/hr = 3.517kW, 1mH2O = 9.8kPa
 2. Fouling factor of water in evaporator is 0.0176m²·°C/kW
 3. Ambient temperature is 35.00°C, Chilled water temperature outlet is 6.67°C, inlet is 12.22°C.
 4. Due to our policy of innovation some specifications may be changed without prior notification.
 5. All data in this table is rated in accordance with AHRI Standard 550/590.

MCAW Series (50Hz, High)

Model		Units	MCAW030CA2B	MCAW036CA3B	MCAW040CA3B	MCAW045CA4B	MCAW050CA4B
Unit Capacity	usRT		299	362	405	444	495
	kW		1,052	1,273	1,424	1,562	1,740
	kcal/h		904,557	1,094,583	1,224,420	1,343,078	1,496,131
Compressors	Power Supply		3 Ph / 380 V / 50 Hz	3 Ph / 380 V / 50 Hz	3 Ph / 380 V / 50 Hz	3 Ph / 380 V / 50 Hz	3 Ph / 380 V / 50 Hz
	Starter Type		Y-DELTA	Y-DELTA	Y-DELTA	Y-DELTA	Y-DELTA
	RLA	A	267 / 234	226 / 226 / 193	239 / 239 / 228	188 / 173 / 188 / 173	218 / 186 / 218 / 186
	Starting Current	A	1,066	1,120	1,248	1,075	1,290
	Refrigerant Circuits	EA	2	3	3	4	4
Evaporator	Inlet/Outlet Temperature	°C	12.22 / 6.67	12.22 / 6.67	12.22 / 6.67	12.22 / 6.67	12.22 / 6.67
	Flow Rate	m ³ /h	162.5	196.5	219.9	241.2	268.8
	Pressure Drop	mAq	13.9	16.8	16.7	5.94	11.1
	Connection	A	150	200	200	150	150
Condenser	Ambient Temperature	°C	35	35	35	35	35
Fans	Number	EA	10 / 8	8 / 8 / 6	8 / 8 / 8	8 / 6 / 8 / 6	8 / 8 / 8 / 8
	Fan Motor Input Power	kW	32.4	39.6	43.2	50.4	57.6
	Total Chiller Airflow	CMM	5,670	6,930	7,560	8,820	10,080
Weight	Shipping Weight	kg	8,200	10,200	11,100	13,400	14,400
	Operating Weight	kg	8,623	10,743	11,721	14,104	15,124
Dimension	Length	mm	8,940	10,910	11,900	13,930	15,900
	Width	mm	2,150	2,150	2,150	2,150	2,150
	Height	mm	2,320	2,320	2,320	2,320	2,320
Refrigerant	kg	130 / 120	100 / 100 / 90	120 / 120 / 110	100 / 90 / 100 / 90	110 / 100 / 110 / 100	
Oil	L	28 / 28	28 / 28 / 23	28 / 28 / 28	23 / 20 / 23 / 20	28 / 23 / 28 / 23	

Note:
 1. 1usRT = 3,024kcal/hr = 3.517kW, 1mH₂O = 9.8kPa
 2. Fouling factor of water in evaporator is 0.0176m²·°C/kW
 3. Ambient temperature is 35.00°C, Chilled water temperature outlet is 6.67°C, inlet is 12.22°C.
 4. Due to our policy of innovation some specifications may be changed without prior notification.
 5. All data in this table is rated in accordance with AHRI Standard 550/590.

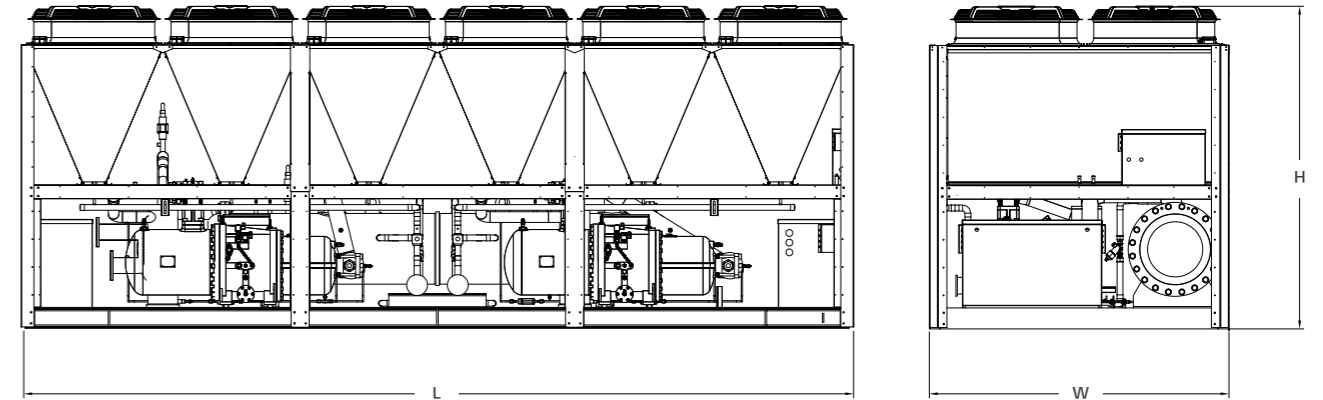
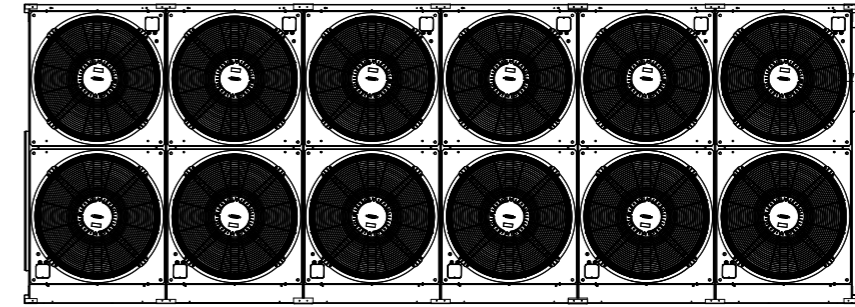

[Tolerance : Chiller dimension ±50 / Unit : mm]

Model	Chiller Dimension			Fan Number
	L	W	H	
RCAW008CA1C	3,020	2,150	2,320	6
RCAW010CA1C	3,020	2,150	2,320	6
RCAW012CA1C	4,010	2,150	2,320	8
RCAW014CA2C	4,010	2,150	2,320	4 / 4
RCAW016CA2C	4,990	2,150	2,320	6 / 4
RCAW018CA2C	5,980	2,150	2,320	6 / 6
RCAW020CA2C	5,980	2,150	2,320	6 / 6
RCAW022CA2C	6,970	2,150	2,320	8 / 6
RCAW024CA2C	6,970	2,150	2,320	8 / 6
RCAW026CA2C	7,950	2,150	2,320	8 / 8
RCAW028CA2C	8,940	2,150	2,320	10 / 8
RCAW030CA2C	9,920	2,150	2,320	10 / 10
RCAW036CA3C	10,910	2,150	2,320	8 / 8 / 6
RCAW040CA3C	11,900	2,150	2,320	8 / 8 / 8
RCAW044CA4C	13,930	2,150	2,320	8 / 6 / 8 / 6
RCAW048CA4C	13,930	2,150	2,320	8 / 6 / 8 / 6
RCAW052CA4C	15,900	2,150	2,320	8 / 8 / 8 / 8

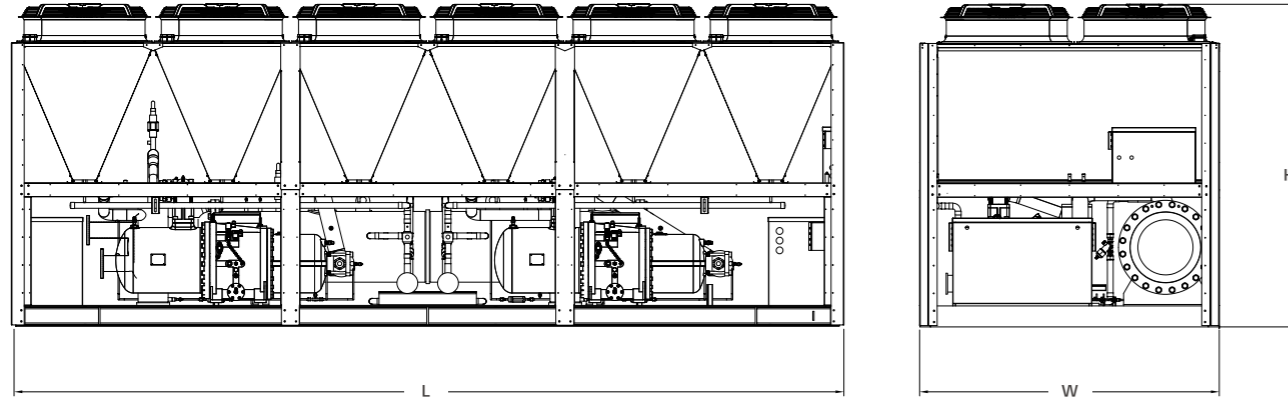
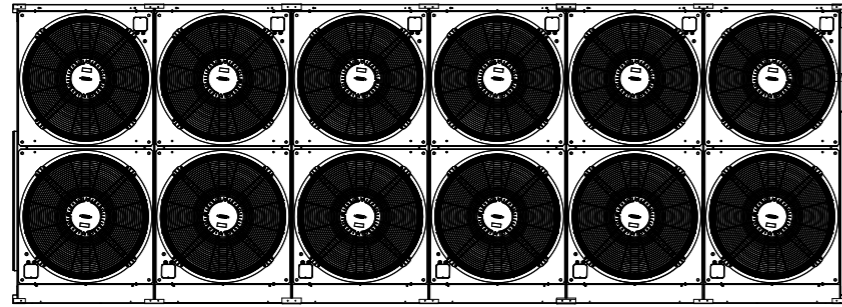

[Tolerance : Chiller dimension ±50 / Unit : mm]

Model	Chiller Dimension			Fan Number
	L	W	H	
MCAW008CA1B	3,020	2,150	2,320	6
MCAW010CA1B	3,020	2,150	2,320	6
MCAW012CA1B	4,010	2,150	2,320	8
MCAW014CA1B	4,010	2,150	2,320	8
MCAW014CA2B	4,010	2,150	2,320	4 / 4
MCAW016CA1B	4,990	2,150	2,320	10 / 4
MCAW016CA2B	4,990	2,150	2,320	6 / 4
MCAW018CA2B	5,980	2,150	2,320	6 / 6
MCAW020CA2B	5,980	2,150	2,320	6 / 6
MCAW022CA2B	6,970	2,150	2,320	8 / 6
MCAW024CA2B	6,970	2,150	2,320	8 / 6
MCAW026CA2B	7,950	2,150	2,320	8 / 8
MCAW028CA2B	8,940	2,150	2,320	10 / 8
MCAW030CA2B	8,940	2,150	2,320	10 / 8
MCAW036CA3B	10,910	2,150	2,320	8 / 8 / 6
MCAW040CA3B	11,900	2,150	2,320	8 / 8 / 8
MCAW045CA4B	13,930	2,150	2,320	8 / 6 / 8 / 6
MCAW050CA4B	15,900	2,150	2,320	8 / 8 / 8 / 8

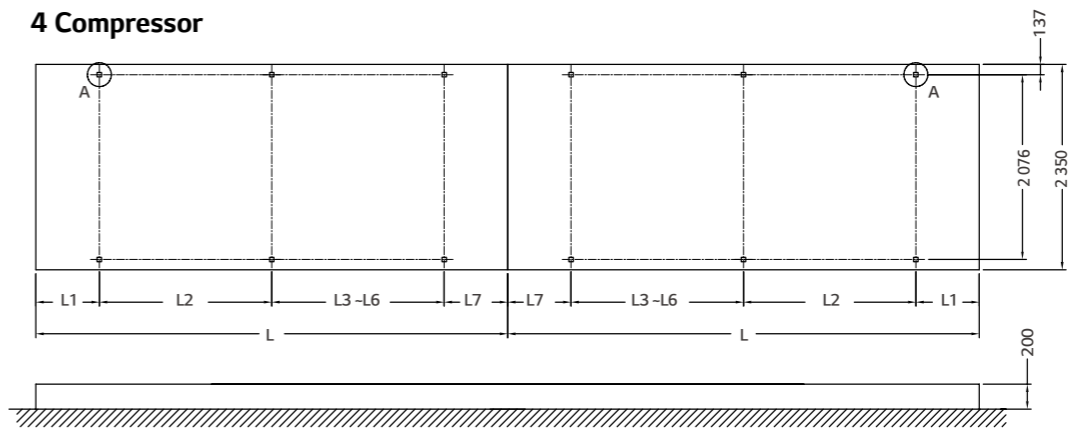
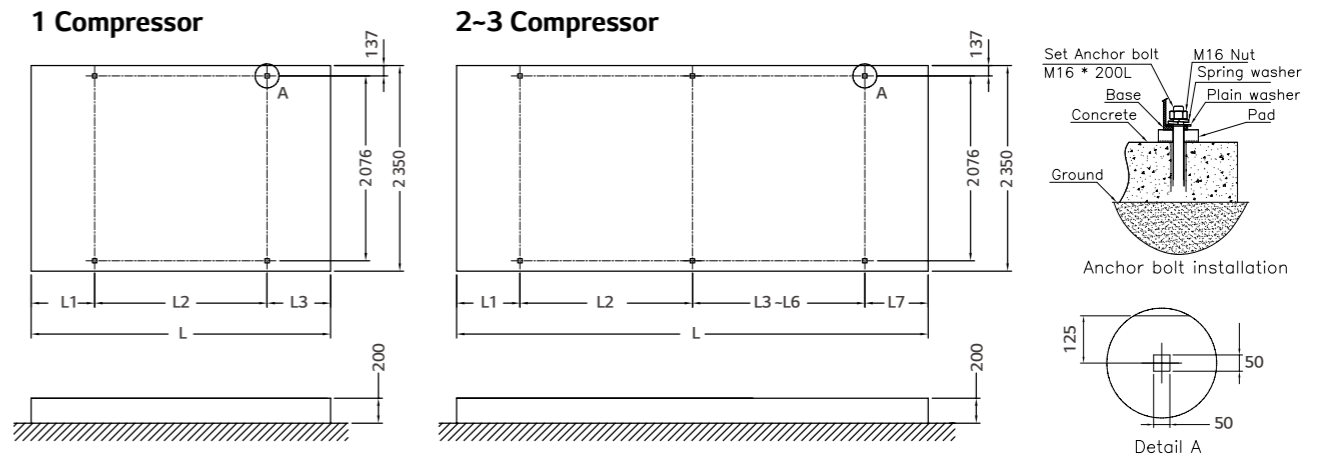

[Unit : mm]

Model	L	L1	L2	L3	L4	L5	L6	L7
RCAW008CA1C	3,422	725	1,972	725				
RCAW010CA1C	3,422	725	1,972	725				
RCAW012CA1C	4,408	725	2,958	725				
RCAW014CA2C	4,408	725	2,958	725				
RCAW016CA2C	5,394	725	1,972	1,972	725			
RCAW018CA2C	6,370	725	1,972	2,958	725			
RCAW020CA2C	6,370	725	1,972	2,958	725			
RCAW022CA2C	7,366	725	1,972	1,972	1,972	725		
RCAW024CA2C	7,366	725	1,972	1,972	1,972	725		
RCAW026CA2C	8,352	725	1,972	1,329	1,629	1,972	725	
RCAW028CA2C	9,338	725	1,972	1,972	1,972	1,972	725	
RCAW030CA2C	10,324	725	1,972	1,972	2,958	1,972	725	
RCAW036CA3C	11,310	725	1,972	1,972	1,972	1,972	1,972	725
RCAW040CA3C	12,296	725	1,972	1,972	2,958	1,972	1,972	725
RCAW044CA4C	7,366	725	1,972	1,972	1,972	725		
RCAW048CA4C	7,366	725	1,972	1,972	1,972	725		
RCAW052CA4C	8,352	725	1,972	1,329	1,629	1,972	725	

1 Compressor

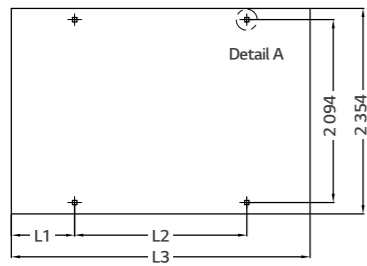

2-3 Compressor

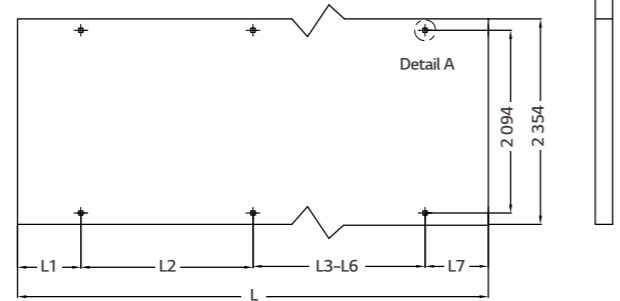

4 Compressor

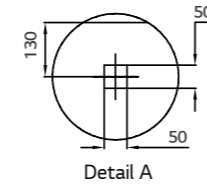
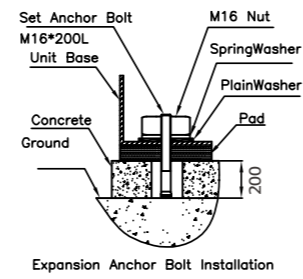
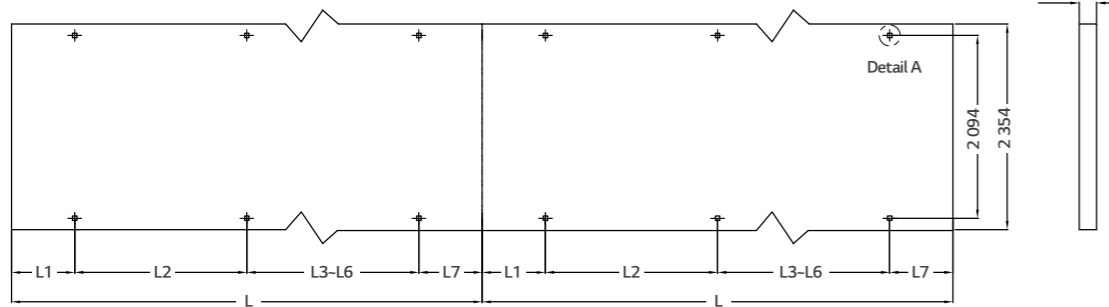

Select installation location

Select space for installation air-cooled unit, which will meet the following conditions

- With strength which bears weight of unit
- With space for air passage and service work, don't install the unit at the space where generation, inflow, stagnation, and leak of combustible gas is expected.
- Avoid unit installation in a place where acidic solution and spray(Sulfur) are often used.
- Location with no leakage of combustible gas
- Location with installation or service work space(Refer to required space)
- Do not use the air-cooled unit under any special environment where oil, steam and sulfuric gas exist.
 - Establish an anti-freeze plan for the water supply when the product is stopped during the winter.
- The floor of the machine room must be water proof.
- In order to prevent the condensed water from being produced, both the evaporator and the pipe connected to it should be insulated.
 - Install a floor slope to make the drainage smooth.
- Avoid installing the air-cooled unit in the location with following conditions.
 - Location where corrosive gas such as acidic gas is generated. (It may cause the refrigerant leakage by corrosion of the pipe.)
 - Location where electromagnetic waves happen. (It may cause the abnormal operation by control parts disorder.)
 - Location to be able to leak the combustible gas
 - Location with carbon fiber or combustible dust.
 - Location with the combustible material like thinner or gasoline. (It may cause a fire by leaking the gas near the product.)

[Unit : mm]

Model	L	L1	L2	L3	L4	L5	L6	L7
MCAW008CA1B	3,422	725	1,972	725				
MCAW010CA1B	3,422	725	1,972	725				
MCAW012CA1B	4,408	725	1,985	1,015	683			
MCAW014CA1B	4,408	725	1,985	1,015	683			
MCAW014CA2B	4,408	725	1,985	1,015	683			
MCAW016CA1B	5,394	725	1,972	1,972	725			
MCAW016CA2B	5,394	725	1,972	1,972	725			
MCAW018CA2B	6,380	565	1,750	1,750	1,750	565		
MCAW020CA2B	6,380	565	1,750	1,750	1,750	565		
MCAW022CA2B	7,366	725	1,972	1,972	1,972	725		
MCAW024CA2B	7,366	725	1,972	1,972	1,972	725		
MCAW026CA2B	8,352	565	1,750	1,750	1,750	1,750	787	
MCAW028CA2B	9,338	725	1,972	1,972	1,972	1,972	725	
MCAW030CA2B	9,338	725	1,972	1,972	1,972	1,972	725	
MCAW036CA3B	11,310	725	1,972	1,972	1,972	1,972	1,972	725
MCAW040CA3B	12,296	1,218	1,972	1,972	1,972	1,972	1,972	1,218
MCAW045CA4B	7,366	725	1,972	1,972	1,972	725		
MCAW050CA4B	8,352	565	1,750	1,750	1,750	1,750	787	

Installation space

Air-cooled chiller should be installed on sufficient space for airflow ventilation and product repair.

Installation space

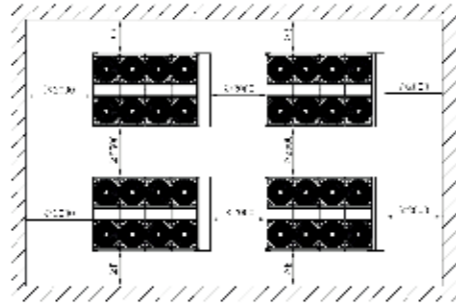
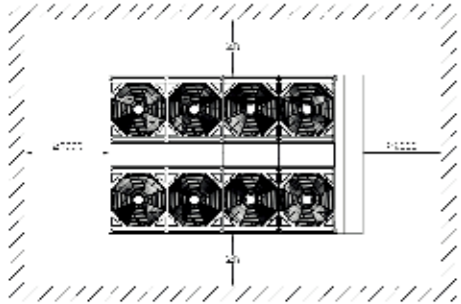

Wall height	B (mm)
≤ 800	≥ 2,000
≥ 800	≥ 3,000

The distance between unit and wall

General

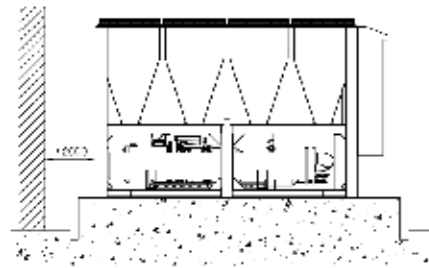

Wall height : Under 800mm

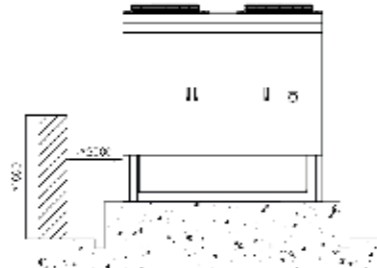

Wall height : Over 800mm

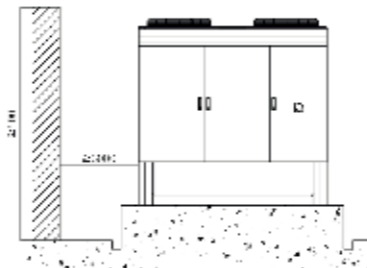

The distance between unit and ceiling

Pillars and ceiling type

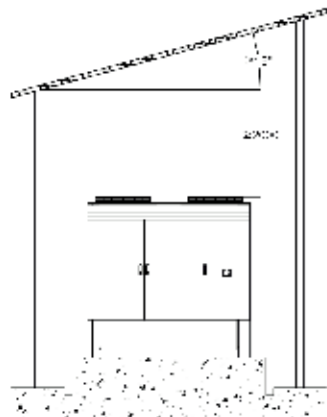

Wall and ceiling type

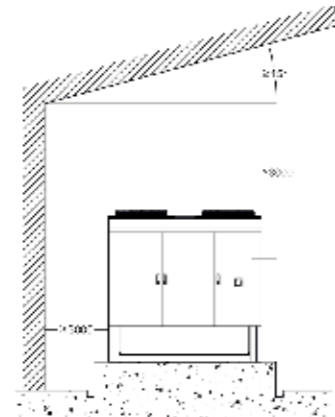

Guide specification

Air Cooled Screw Chiller
RCAW C Series

Contents

1. Range of application
2. Equipment features
3. Equipment specifications
4. Scope of construction
5. Supply range
6. The warranty and service
7. General details
8. Caution details



Guide specification



1. Range of application

This specification applies to all the models of Air-Cooled SCREW RCAW(C) conducting and selling at LG Electronics.

2. Equipment features

- 1) To improve the performance of heat exchange, the gas/liquid refrigerant separator is installed inside falling film type evaporator, and the structure of being able to drip the separated liquid refrigerant uniformly on tube bundle.
- 2) Cyclone type oil separator with structure that separates oil and refrigerant using vortex and gravity shall be installed.
- 3) To keep oil concentration inside evaporator at the below standard, oil reclaim system shall be applied.
- 4) Limit control is implemented to prevent unit stop due to abnormal condition. A control algorithm should be applied to minimize manual reset and restart.
- 5) This items shall be applied
 - Evaporator pressure transmitter
 - Condenser pressure transmitter
 - High pressure switch
 - Chilled water inlet/outlet temperature sensor
 - Cooling water inlet/outlet temperature sensor
 - Compressor discharge temperature sensor
- 6) It is designed to be able to check and set the data with 7 inches touch screen controller.
- 7) An oil level switch should be applied to prevent damage to the compressor in case of insufficient oil.

3. Equipment specifications

3.1. System composition

- 1) The chiller uses the Semi-hermetic, rotary twin Screw type compressor, to compressing the refrigerant for cooling, and chilled water outlet temperature is PID controlled by microprocessor controller.
- 2) Steel plate and pipe are performed the surface treatment to prevent corrosion.
- 3) Before shipping and start-up commissioning, the ni-trogen gas shall be charged with a pressure of 0.3~0.5kg/cm²G to check whether the product is leaked and prevent the air inflow.
- 4) Water-cooled screw chiller is all-in-one and produced for convenient installation, operation and maintenance management and compactly to minimize the area of installation and space.
- 5) The customer supplies each power wire for each compressor, depending on the compressor quantity.
- 6) The Open Wiring method is applied for wiring between the chiller main body and the control panel.

3.2. Performance and quality

- 1) The refrigerant, R-134a, environmental refrigerant with Ozone Depleting Potential(ODP) of zero, shall be applied.
- 2) The pressure vessel should be designed, produced, tested, complying with KGS Code, and certified in the authorized institute.

3.3. Equipment specification

3.3.1. Equipment composition

- 1) Screw compressor
- 2) Evaporator
- 3) Condenser
- 4) External oil separator
- 5) Oil reclaim system
- 6) Ref. piping
- 7) Safety devices
- 8) Control panel
- 9) Starter Panel : The stater panel is supplied by the manufacturer with the chiller.
The starter panel is attached and installed to the chiller unit.

3.3.2. Screw compressor

- 1) The twin rotor/semi-hermetic type compressor and refrigerant-cooled motor shall be used.
- 2) A differential pressure type oil lubrication and em-bedded type filter shall be applied.
- 3) The compressor embedded type oil separator shall be used and the check valve to prevent the refrigerant from flowing backward on the discharge side shall be installed.
- 4) By using the slide valve for control the capacity, chiller is used 3~4 step type controllable for 25(35)%-100%.
- 5) Attaches the Discharge/Suction Shut Off V/V.
- 6) Install the oil differential pressure switch(For filter)
- 7) Install the oil level switch(For oil)
- 8) The starter type of compressor motor is Y-D.

3.3.3. Evaporator

- 1) The heat exchanger is manufactured in Shell & Tube type.
- 2) To improve the performance of heat exchanging, the gas/liquid refrigerant separator is installed inside falling film type evaporator, and the structure of being able to drip the separated liquid refrigerant uniformly on tube bundle.
- 3) The high-efficiency heat-transfer tubes with seamless phosphorus deoxidized Copper shall be used, and the steel plate or steel pipe are used for Shell.
- 4) The tubes shall be combined with mechanical expansion on the tube sheet so that it can be replaced.
- 5) The flow detection switch is installed to prevent the chilled water from freezing on the chilled water side.
- 6) Install oil reclaim tube from evaporator to compressor, to

- keep oil concentration inside evaporator at a below standard.
- 7) The heat-transfer tubes shall be machined to improve heat transfer performance inside and outside the tube and parts in contact with tube sheets and tube support plates shall not be machined. The tube support plates for heat-transfer tubes shall be designed for stable support of heat-transfer tubes in accordance with TEMA and ASME standards.
 - 8) The design pressure of the evaporator water box is 10kg/cm²(150 psig).
 - 9) It should be a structure available to do air vent on top of the water box and drain at the bottom of the water box.

3.3.4. Condenser

- 1) The heat exchanger is manufactured in Shell & Tube type.
- 2) The high-efficiency heat-transfer tubes with seamless phosphorus deoxidized Copper tube shall be used, and the steel plate or steel pipe are used for Shell.
- 3) The tubes shall be combined with mechanical expansion on the tube sheet so that it can be replaced.
- 4) The condenser must have an anti-collision plate installed at the gas inlet, and the anti-collision plate must have a structure that allows noise reduction and stable diffusion of flow paths. In order to ensure the subcooling, built-in subcooler installed inside condenser.
- 5) The heat-transfer tubes shall be machined to improve heat transfer performance inside and outside the tube and parts in contact with tube sheets and tube support plates shall not be machined. The tube support plates for heat-transfer tubes shall be designed for stable support of heat-transfer tubes in accordance with TEMA and ASME standards.
- 6) 7) It should be a structure available to do air vent on top of the water box and drain at the bottom of the water box.

3.3.5. External oil separator

- 1) A vertical type of pressure vessel shall be manufactured.
- 2) The material of shell shall be steel pipe.
- 3) Cyclone type oil separator with structure that separates oil and refrigerant using vortex and gravity shall be installed.

3.3.6. Oil reclaim system

- 1) To reclaim oil mixed with the refrigerant from the evaporator to compressor, it should be installed the ejector(Spray ejector) available of oil return without consuming the additional energy.

3.3.7. Refrigerant pipe

- 1) The refrigerant pipes are installed for refrigerant flow between each composition to be smooth, using the carbon steel pipe(KSD 3562, SPPS38E) for pressure pipe and seamless phosphorus deoxidized copper pipe of more than

99.9% purity.

- 2) Check valve should be installed in the compressor discharge so that discharged refrigerant flow cannot flow backward.
- 3) By installing the filter dryer at the pipe, It should be absorbed the moisture in the internal pipe and filtered the foreign substance.
- 4) From the expansion valve to the evaporator, pipe should be applied insulation to prevent the moisture of the pipe surface from condensing and the occurring of flash gas of refrigerant liquid at the same time.
- 5) After production and run a leak test, vacuuming should be done completely not to have any moisture inside.

3.3.8. Automatic control panel

1) Control device

a. The composition of control panel.

The protection grade of control panel is IP54.

The control panel consists of microprocessor controller (Main controller and Display), power supply system to supply the stable power, breaker to perform the other control or secure the safety, magnetic contactor, and control relay, and a primary feature of each module is as below.

b. Main Controller

It is implemented the control feature optimized to the mechanical device by applying the high-performance microprocessor. the high resolution A/D convertor (Analogue/Digital) shall be applied to display on screen or control by measuring each kind of temperature sensor value in real time.

Also, it makes the customer's building automation ease response because the RS-485 communication port to support the customer's remote surveillance control is embedded in a standard.

It consists of the digital input part to check each kind of operation state of the switch and the digital output part to control the operation of chiller.

Also, the input/output port has a photocoupler blocking each kind of noise. Since all data is transmitted and received with the main module through communication, it secures high reliability by preventing the malfunction caused by electromagnetic wave to happen when transmitting and receiving the data of general cable.

c. Display

The machine run/stop state important for operation, abnormal state, operation data can be checked on the display, and input setting needed to equipment operating.

Also, it made the operator's operation convenience by choosing and displaying the operation state(Temperature, run/stop and save of the peripheral device) into Korean, Chinese and English on the display part.

2) The feature of control device

a. The convenient operating data management

It makes much operation information checked on one screen simultaneously by applying the 7 inches color graphic liquid crystal display. In addition, It also makes analog data(ex: temperature data) used when recording drive operation reports and managing the maintenance by saving 300 cases for each channel in the time interval set by the customer. Also, it makes the trend of temperature change easily identified by displaying the chilled water outlet temperature on a graph in real-time.

b. The safety control algorithm

It implement the preventive operation without an abnormal stop in advance by detecting the high/low-pressure sensor, discharge temperature sensor, current sensor, which are the safety device of digital output. It is possible to continuous operate without chiller stop because the algorithm that removing the inconvenience of manual reset work to restart by minimizing the number of abnormality occurring is implemented.

c. Self-diagnosis and save of abnormality history.

Micom makes monitor the chiller state during chiller stop or running, making a notice to operator using a message or buzzer making an auto-saving of failure data and occurring time which can be utilized in repairing conveniently. Especially, as there is help function on the on the abnormality history, it is possible to respond and make an action promptly because the content about cause of occurrence, inspection and how to react are displayed. In addition, it is also possible to check the operation/ abnormality history on the control device because the history is saved up to 300 in order.

d. Optimized AI type control algorithm.

Soft start

It makes the input current gradually control to prevent machinery shock caused by sudden increase in load when starting.

- Advanced digital PID control

When starting or changing the operating mode from manual to automation, by perceiving the optimized PID control point automatically and reflecting it in the control equation, compared with the conventional analog control, the digital PID control that combined with soft start makes unnecessary machinery stop minimize and makes more stable and precised temperature control.

* The digital transmitter for evaporator pressure/condenser pressure monitoring.

* The Digital Transmitter for current display/monitoring.

* Installation of PT 100 Sensor for chilled water/cooling water temperature.

- Scheduled operating function(Reserved operation)
It makes the convenience on chiller operation by

applying the schedule operation function available to choose the run/stop and control temperature setting for each day, particular holiday, or 11 times a day.

e. Strong customer support function

- Communication function for building automation and remote monitoring control

It is equipped with the Modbus communication function available to conveniently connected with the customer's monitoring system.

The zero voltage input/output shall be provided to run /stop in the remote or to monitor the run state of the machine using the simple electric wiring.

- Help function

If the breakdown occurs, it promote the operator's convenience by recording failure details, and showing clarification of how to respond if the operator selects the type of failure from the menu.

- Available for support of three languages

It is supported that the function to select/use Korean, Chinese, and English in the operation menu.

f. To operate at partial load condition, the step compressor capacity control method is applied.

3.3.9. Starter panel

- 1) The protection grade of starter panel is IP54.

3.3.10. Safety devices

- 1) The complete compressor protective function from external electric shock shall be provided by embedding the dual protective device about reverse phase/phase loss/over-current.

2) Safety device for chilled water and cooling water

- a. Chilled water pump interlock point of contact
- b. Cooling water pump interlock point of contact
- c. The chilled water/cooling water flow differential pressure switch.

d. Chilled water temperature(low): the below 2.9°C of chilled water outlet temperature.

※ The run/stop signal and interlock point of contact for the chilled/cooling water pump is the important safety device for protecting chilled water freezing and safety accidents, so chiller, chilled water pump and cooling water pump should be linked in operation by wiring connection.

※ Also, when several cooling water pipes are connected in parallel, automatic shut-off valve must be installed to prevent water from flowing into the cooling water pipe of the corresponding chiller, and then the automatic shut-off valve must be opened and closed by interlocking with the control device. The interlocking method of the automatic shutoff valve should open and close in synchronization with the cooling water pump run/stop signal provided by the LG Electronics control panel.

e. For the details, it should be discussed with LG Electronics in advance.

3) The chiller protective device

- a. [The low-pressure sensor] for protection of the chiller in case of abnormal low pressure of evaporator.
- b. [The high-pressure sensor] for protection of the chiller in case of abnormal high pressure of condenser.
- c. [The oil differential pressure switch] for protection of the compressor in case of abnormal oil differential pressure.
- d. [The oil level switch] for protection of the compressor in case of abnormal oil level.
- e. [The chilled water flow differential pressure switch] for protection of the chiller in case of abnormal chilled water flow.
- f. [The cooling water flow differential pressure switch] for protection of the chiller in case of abnormal cooling water flow.
- g. [The temperature sensor of chilled water inlet/outlet] to protect the chiller in case of abnormal temperature of chilled water inlet/outlet.
- h. [The temperature sensor of cooling water inlet/outlet] to protect the chiller in case of abnormal temperature of cooling water inlet/outlet.
- i. [The temperature sensor of compressor discharge] to protect the overheat of the chiller in case of abnormal high discharge temperature.
- j. [The protective relay] to protect the overcurrent.
- k. The safety valve [evaporator]. In case of abnormal high pressure, refrigerant is discharged to protect the chiller.

4) Motor/compressor protective device

- a. Reverse phase/phase loss protective relay
- b. Temperature switch for monitoring of motor winding temperature
- c. Temperature sensor for monitoring of compressor discharge temperature

3.3.11. Isolator

- 1) The vibration proof pad for vibration isolator device is supplied.

4. Scope of construction

Item	Supplied by	Note
Painting	LG Electronics	Main body : Dawn gray Starter panel, Control panel : Warm gray
Cold insulation	LG Electronics	Cold-insulate the external side of evaporator, chilled water box, and compressor motor Material : NBR 19mm
Transportation and installation	LG Electronics	Transportation installation of installation place or basis
Leaking test, Insulation test, Put the refrigerant	LG Electronics	The work doing before start-up commissioning at the installation place
External piping	Consumer	Mean the external pipe construction such as chilled water, cooling water and drain
Building and basis	Consumer	Prepare the basis construction for chiller installation before its installation
Chiller horizontality work	LG Electronics	The work at the time of chiller installation
Start-up commissioning and operating guidance	LG Electronics	Conduct 1 time a day(8 hours) (Supply the necessary electricity, chilled water, cooling water)
Interlock wiring work for chilled water, cooling water pump	Consumer	Wiring between control panel and pump control panel
Nitrogen gas filling up	Consumer	The gas filling up for local keep (if chiller won't be operated for a long time after start-up commissioning)

5. Supply range

Item	Whether if supply or not	Note
Chiller body	LG Electronics	Refer to the body components
The chiller instruction manual	LG Electronics	Installation and operation manual
Starter panel	LG Electronics	Starter system of compressor motor
Vibration proof pad	LG Electronics	The pad for vibrational absorption
Packing	LG Electronics	Shrink film

6. The warranty and service

- 6.1. Standard warranty period is 12 Months from date of commissioning or 18 Months from the date of shipment(STD) from factory whichever comes first. It's valid only if start up & commissioning work is carried out by certified LG Electronics service. Also, warranty shall not apply, if the Products have been subjected to misuse, abuse, negligence, improper installation, improper maintenance, improper transportation, accident, alteration or design change by anyone other than LGE.
- 6.2. Failure, caused by a defect in the parts, material, or operation during the warranty period, will be inspected by LG ELECTRONICS and fixed free of charge if it is agreed that it is defective.
- 6.3. For the following, LG ELECTRONICS don't fix free of charge.
 - 1) If a failure occurs after the product is repaired at the shop that is not designated by LG ELECTRONICS.
 - 2) If the failure is caused by user's mistakes in using and handling the equipment.
 - 3) The monopoly or handover to other places during the warranty period.
 - 4) If a failure is caused by a fire or a natural disaster.

7. General details

- 7.1. Before producing the chillers, getting the approval is required by submitting all the details about production to the customer and the production should be implemented after getting a permit in the negotiation with the customer, as for the details not included marked in these specifications
- 7.2. Before the disposal of the product, if you monopoly or hand it over to others, you should inform LG electronics.

8. Caution details

- 8.1. In case of drain work is progressed after completing the hydraulic pressure test or the circulation test of chilled/cooling water before the start-up and commissioning of the chiller, the chiller should be kept with opening each drain valve of pipe because the freeze and burst can occur by remaining water under the environmental condition of below 0°C outdoor temperature.(Until filling up the make-up water)

Guide specification

Air Cooled Screw Chiller MCAW C Series

Contents

1. Range of application
2. Equipment features
3. Equipment specifications
4. Scope of construction
5. Supply range
6. The warranty and service
7. General details
8. Caution details

Guide specification

1. Range of application

This specification applies to all the model line-up of Air-cooled SCREW MCAW(C) producing and selling at LG Electronics.

2. Equipment features

- 1) To improve the performance of heat exchange, a falling film device is installed inside falling film type evaporator, and the structure of being able to drip the separated liquid refrigerant uniformly on tube bundle.
- 2) Chiller is applied the electronic expansion valve to electrically control the flow of refrigerant.
- 3) Cyclone type oil separator with structure that separates oil and refrigerant using vortex and gravity shall be installed.
- 4) To keep oil concentration inside evaporator at the below standard, oil reclaim system shall be applied.
- 5) Limit control is implemented to prevent unit stop due to abnormal condition. A control algorithm should be applied to minimize manual reset and restart.
- 6) This items shall be applied
 - Evaporator pressure transmitter
 - Condenser pressure transmitter
 - High pressure switch
 - Chilled water inlet/outlet temperature sensor
 - Compressor discharge temperature sensor
 - Compressor suction temperature sensor
 - Ambient temperature sensor
- 7) It is designed to be able to check and set the data with 7inches touch screen controller.
- 8) An oil level switch should be applied to prevent damage to the compressor in case of insufficient oil.
- 9) The product shall satisfy the performance requirements of AHRI(Air Conditioning, Heating And Refrigeration Institute) Latest Standard 550-590/551-591, the international authorized certified institute, and applies the product getting the certification.

3. Equipment specifications

3.1. System composition

- 1) The chiller uses the Semi-hermetic, rotary twin screw type compressor, to compressing the refrigerant for cooling and chilled water outlet temperature is PID controlled by microprocessor controller.
- 2) Steel plate and pipe are performed the surface treatment to prevent corrosion.
- 3) Before shipping and start-up commissioning, the nitrogen gas shall be charged with a pressure of 0.3~0.5kg/cm²G to check whether the product is leaked and prevent the air inflow.
- 4) Air-cooled screw chiller is all-in-one and produced for convenient installation, operation and maintenance management and compactly to minimize the area of in-

stallation and space.

- 5) The customer supplies each power wire for each compressor, depending on the compressor quantity.
- 6) The open wiring method is applied for wiring between the chiller main body and the control panel.

3.2. Performance and quality

- 1) The product performance should be evaluated complying with the standard of AHRI(Air Conditioning, Heating And Refrigeration Institute) Standard 550-590/551-591, the international authorized certified institute.
- 2) The refrigerant, R-134a, environmental refrigerant with Ozone Depleting Potential(ODP) of zero, shall be applied.

3.3. Equipment specification

3.3.1. Equipment composition

- 1) Screw compressor
- 2) Evaporator
- 3) Condenser
- 4) Expansion devices
- 5) Oil separator
- 6) Oil reclaim system
- 7) Ref. piping
- 8) Safety devices
- 9) Control panel
- 10) Starter panel : The starter panel is supplied by the manufacturer with the chiller. The starter panel is attached and installed to the chiller unit.

3.3.2. Screw compressor

- 1) The twin rotor/semi-hermetic type compressor and refrigerant-cooled motor shall be used.
- 2) A differential pressure type oil lubrication and embedded type filter shall be applied.
- 3) The compressor embedded type oil separator shall be used and the check valve to prevent the refrigerant from flowing backward on the discharge side shall be installed.
- 4) By using the slide valve for control the capacity, chiller is used 3~4 step type controllable for 25(35)%~100%.
- 5) Attaches the Discharge/Suction Shut Off V/V.
- 6) Install the oil differential pressure switch(For filter)
- 7) Install the oil level switch(For oil)
- 8) The power specifications of the motor for compressor is three-phase, 380V, 50Hz.
- 9) The starter type of compressor motor is Y-D.

3.3.3. Evaporator

- 1) The heat exchanger is manufactured in Shell & Tube type.
- 2) To improve the performance of heat exchange, a falling film device is installed inside falling film type evaporator, and the structure of being able to drip the separated liquid refrigerant uniformly on tube bundle.
- 3) The high-efficiency heat-transfer tubes with seamless

- phosphorus deoxidized Copper shall be used, and the steel plate or steel pipe are used for Shell.
- 4) The tubes shall be combined with mechanical expansion on the tube sheet so that it can be replaced.
 - 5) The flow detection switch is installed to prevent the chilled water from freezing on the chilled water side.
 - 6) Install oil reclaim tube from evaporator to compressor, to keep oil concentration inside evaporator at the below standard.
 - 7) The heat-transfer tubes shall be machined to improve heat transfer performance inside and outside the tube and parts in contact with tube sheets and tube support plates shall not be machined. The tube support plates for heat-transfer tubes shall be designed for stable support of heat-transfer tubes in accordance with GB standards.
 - 8) On the top of evaporator, the safety valve should be installed according to GB Code.
 - 9) The design pressure of the evaporator water box is 10kg/cm² (150 psig).
 - 10) It should be a structure available to do air vent on top of the water box and drain at the bottom of the water box.

3.3.4. Condenser

- 1) The condenser heat-transfer tubes use the seamless phosphorus deoxidized copper tubes, and aluminum fin was attached to copper tube to increase the heat transfer area.(Cross fin & tube type).
- 2) For efficient heat exchange, aluminum fins must be in contact with the copper tube through mechanical expansion.
- 3) It should cleaning after complete production.
- 4) The pressure test on the refrigerant side of high-pressure should be implemented at 1.1 times of design pressure and there should be no abnormalities such as leakage, deformation, etc.
- 5) The condenser coil passed at the pressure test removes the moisture entirely inside by vacuum drying.
- 6) The stop valve for refrigerant pump down and the safety valve protecting chillers by discharging refrigerant in case of temperature rising extremely due to fire should be installed on pressure vessel.
- 7) The fan should use the propeller(propeller type) and should be able to generate enough air volume needed to condense. Also, it shall be had enough strength to the number of rotations and shall be operated at low noise level through the balance test.
- 8) The fan motor should have F grade of insulation, waterproof grade IP55.
- 9) The fan and motor should be direct drive type.
- 10) The Gold Fin applies to improve the corrosion-proof performance of the heat exchange pin.

3.3.5. Expansion device

- 1) Chiller is applied the electronic expansion valve to electrically control the flow of refrigerant.

3.3.6. Oil separator

- 1) A vertical type of pressure vessel shall be manufactured.
- 2) The material of shell shall be steel pipe.
- 3) Cyclone type oil separator with structure that separates oil and refrigerant using vortex and gravity shall be installed.

3.3.7. Oil reclaim system

- 1) To reclaim oil mixed with the refrigerant from the evaporator to compressor, it should be installed the ejector(Spray ejector) available of oil return without consuming the additional energy.

3.3.8. Refrigerant pipe

- 1) The refrigerant pipes are installed for refrigerant flow between each composition to be smooth, using the carbon steel pipe for pressure pipe and seamless phosphorus deoxidized copper pipe of more than 99.9% purity.
- 2) Check valve should be installed in the compressor discharge so that discharged refrigerant flow cannot flow backward.
- 3) By installing the filter dryer at the pipe, It should be absorbed the moisture in the internal pipe and filtered the foreign substance.
- 4) From the expansion valve to the evaporator, pipe should be applied insulation to prevent the moisture of the pipe surface from condensing and the occurring of flash gas of refrigerant liquid at the same time.
- 5) After production and run a leak test, vacuuming should be done completely not to have any moisture inside.

3.3.9. Automatic control panel

1) Control device

a. The composition of control panel

The Protection grade of the control panel is IP54.

The control panel consists of microprocessor controller (Main controller and Display), power supply system to supply the stable power, breaker to perform the other control or secure the safety, magnetic contactor, and control relay, and a primary feature of each module is as below.

b. Main controller

It is implemented the control feature optimized to the mechanical device by applying the high-performance microprocessor, the high resolution A/D convertor(Analogue/Digital) shall be applied to display on screen or control by measuring each kind of temperature sensor value in real time.

Also, it makes the customer's building automation ease response because the RS-485 communication port to

support the customer's remote surveillance control is embedded in a standard.

It consists of the digital input part to check each kind of operation state of the switch and the digital output part to control the operation of chiller.

Also, the input/output port has a photocoupler blocking each kind of noise. Since all data is trans-mitted and received with the main module through communication, it secures high reliability by preventing the malfunction caused by electromagnetic wave to happen when transmitting and receiving the data of general cable.

c. Display

The machine run/stop state important for operation, abnormal state, operation data can be checked on the display, and input setting needed to equipment operating.

Also, it made the operator's operation convenience by choosing and displaying the operation state (Temperature, run/stop and save of the peripheral device) into Korean, Chinese and English on the display part.

2) The feature of control device

a. The convenient operating data management

It makes much operation information checked on one screen simultaneously by applying the 7 inches color graphic liquid crystal display. In addition, It also makes analog data(ex: temperature data) used when recording drive operation reports and managing the maintenance by saving 300 cases for each channel in the time interval set by the customer. Also, it makes the trend of temperature change easily identified by displaying the chilled water outlet temperature on a graph in real-time.

b. The safety control algorism

It implement the preventive operation without an abnormal stop in advance by detecting the high/low-pressure sensor, discharge temperature sensor, current sensor, which are the safety device of digital output. It is possible to continuous operate without chiller stop because the algorism that removing the inconvenience of manual reset work to restart by minimizing the number of abnormality occurring is implemented.

c. Self-diagnosis and save of abnormality history

Micom makes monitor the chiller state during chiller stop or running, making a notice to operator using a message or buzzer making an auto-saving of failure data and occurring time which can be utilized in repairing conveniently.

Especially, as there is help function on the on the abnormality history, it is possible to respond and make an action promptly because the content about cause of occurrence, inspection and how to react are displayed.

In addition, it is also possible to check the operation/ abnormality history on the control device because the history is saved up to 300 in order.

d. Optimized AI type control algorism.

Soft start

It makes the input current gradually control to pre-vent machinery shock caused by sudden increase in load when starting.

- Advanced digital PID control

When starting or changing the operating mode from manual to automation, by perceiving the optimized PID control point automatically and reflecting it in the control equation, compared with the conventional analog control, the digital PID control that combined with soft start makes unnecessary machinery stop minimize and makes more stable and precised temperature control.

* The digital transmitter for evaporator pressure/condenser pressure monitoring.

* The Digital Transmitter for current display/monitoring.

* Installation of PT 100 Sensor for chilled water/cooling water temperature

- Scheduled operating function(Reserved operation)

It makes the convenience on chiller operation by applying the schedule operation function available to choose the run/stop and control temperature setting for each day, particular holiday, or 11 times a day.

e. Strong customer support function

- Communication function for building automation and remote monitoring control.

It is equipped with the Modbus communication function available to conveniently connected with the customer's monitoring system. The zero voltage input/output shall be provided to run/stop in the remote or to monitor the run state of the machine using the simple electric wiring.

- Help function

If the breakdown occurs, it promote the operator's convenience by recording failure details, and showing clarification of how to respond if the operator selects the type of failure from the menu.

- Available for support of three languages

It is supported that the function to select/use Korean, Chinese, and English in the operation menu.

f. To operate at partial load condition, the step compressor capacity control method is applied.

3.3.10. Starter panel

1) The protection grade of starter panel is IP54.

2) NFB(Molded case circuit breaker) including the handle available to control the breaker from the outside of the panel applies.

3.3.11. Safety devices

1) The complete compressor protective function from external electric shock shall be provided by embedding the

dual protective device about reverse phase/phase loss/overcurrent.

- 2) safety device for chilled water
 - a. Chilled water pump Interlock point of contact
 - b. Chilled water differential pressure switch
 - c. Chilled water temperature(low) : below 2.9°C of chilled water outlet temperature
 - d. ※ The run/stop signal and interlock point of contact of the chilled water pump is the important safety device for protecting chilled water freezing and safety accidents, so chiller and chilled water pump should be linked in operation by wiring connection.
 - e. For the details, it should be discussed with LG Electronics in advance.
- 3) The chiller protective device
 - a. [The low-pressure sensor] for protection of the chiller in case of abnormal low pressure of evaporator.
 - b. [The high-pressure sensor] for protection of the chiller in case of abnormal high pressure of condenser.
 - c. [The oil differential pressure switch] for protection of the compressor in case of abnormal oil differential pressure.
 - d. [The oil level switch] for protection of the compressor in case of abnormal oil level.
 - e. [The chilled water differential pressure switch] for protection of the chiller in case of abnormal chilled water flow.
 - f. [The temperature sensor of chilled water inlet/outlet] to protect the chiller in case of abnormal temperature of chilled water inlet/outlet.
 - g. [The temperature sensor of compressor discharge] to protect the overheat of the chiller in case of abnormal high discharge temperature.
 - h. [The protective relay] to protect the overcurrent.
- 4) Motor/compressor protective device
 - a. Reverse phase/phase loss protective relay
 - b. Temperature switch for monitoring of motor winding temperature
 - c. Temperature sensor for monitoring of compressor discharge temperature
 - d. The overcurrent protective relay of fan motor
- 5) The safety valve[evaporator]. In case of abnormal high pressure, refrigerant is discharged to protect the chiller.

3.3.12. Isolator

- 1) The vibration proof pad for vibration isolator device is supplied.

4. Scope of construction

Item	Supplied by	Note
Painting	LG Electronics	Main body : Morning gray Starter panel, Control panel : Warm gray
Cold insulation	LG Electronics	Cold-insulate the external side of evaporator, chilled water box, and compressor motor Material : NBR 19mm
Transportation and installation	LG Electronics	Transportation installation of installation place or basis
Leaking test, Insulation test, Put the refrigerant	LG Electronics	The work doing before start-up commissioning at the installation place
External piping	Consumer	Mean the external pipe construction such as chilled water and drain
Building and basis	Consumer	Prepare the basis construction for chiller installation before its installation
Chiller horizontality work	LG Electronics	The work at the time of chiller installation
Start-up commissioning and operating guidance	LG Electronics	Conduct 1 time a day(8 hours) (Supply the necessary electricity, chilled water)
Interlock wiring work for chilled water, cooling water pump	Consumer	Wiring between control panel and pump control panel
Nitrogen gas filling up	Consumer	The gas filling up for local keep (if chiller won't be operated for a long time after start-up commissioning)

5. Supply range

Item	Whether if supply or not	Note
Chiller body	LG Electronics	Refer to the body components
Refrigerant (R-134a)	LG Electronics	Separate delivery
The chiller instruction manual	LG Electronics	Installation and operation manual
Starter panel	LG Electronics	Starter system of compressor motor
Vibration proof pad	LG Electronics	The pad for vibrational absorption
Packing	LG Electronics	Shrink film

6. The warranty and service

- 6.1. Standard warranty period is 12 Months from date of commissioning or 18 Months from the date of shipment (STD) from factory whichever comes first. It's valid only if start up & commissioning work is carried out by certified LG Electronics service. Also, warranty shall not apply, if the Products have been subjected to misuse, abuse, negligence, improper installation, improper maintenance, improper transportation, accident, alteration or design change by anyone other than LGE.

- 6.2. Failure, caused by a defect in the parts, material, or operation during the warranty period, will be inspected by LG ELECTRONICS and fixed free of charge if it is agreed that it is defective.
- 6.3. For the following, LG ELECTRONICS don't fix free of charge.
 - 1) If a failure occurs after the product is repaired at the shop that is not designated by LG ELECTRONICS.
 - 2) If the failure is caused by user's mistakes in using and handling the equipment.
 - 3) The monopoly or handover to other places during the warranty period
 - 4) If a failure is caused by a fire or a natural disaster.

7. General details

- 7.1. Before producing the chillers, getting the approval is required by submitting all the details about production to the customer and the production should be implemented after getting a permit in the negotiation with the customer, as for the details not included marked in these specifications.
- 7.2. Before the disposal of the product, if you monopoly or hand it over to others, you should inform LG electronics.

8. Caution details

- 8.1. In case of drain work is progressed after completing the hydraulic pressure test or the circulation test of chilled/cooling water before the start-up and commissioning of the chiller, the chiller should be kept with opening each drain valve of pipe because the freeze and burst can occur by remaining water under the environmental condition of below 0°C outdoor temperature.(Until filling up the make-up water)

